



# PRODUCT CATALOGUE

2025

[www.rigpl.com](http://www.rigpl.com)



# Core Competencies:

## Industry Leadership

ROHIT has consistently positioned itself at the forefront of the HSS and Solid Carbide Cutting Tools industry since its inception in 1963 under the leadership of Mr. K.L. Duggal. The company has evolved from humble beginnings to a recognized brand synonymous with quality and reliability in cutting tools. The strategic direction of ROHIT is guided by our Chairman, whose vision has been instrumental in steering the company towards sustained growth and innovation in the cutting tools sector..

## Manufacturing Expertise

With over six decades of experience in the production of HSS and Solid Carbide Cutting Tools, ROHIT has developed a robust manufacturing capability. Our facilities encompass two state-of-the-art manufacturing units, totaling over 40,000 square feet, equipped with advanced machinery to ensure precision and quality.

## Research and Development Team

Our RD team comprises highly qualified engineers from India's premier engineering institutions, dedicated to advancing the design and functionality of Carbide Cutting Tools. This team focuses on enhancing productivity, improving repeatability, and minimizing CPC.

## Heat Treatment Facility

Leveraging over 60 years of expertise in HSS heat treatment processes, ROHIT ensures the delivery of high-performance HSS tools that consistently meet rigorous industry standards.

## Product Knowledge

Our workforce, comprising experienced employees and engineers, possesses extensive knowledge accrued over six decades in the cutting tool industry. Concurrently, our RD center is committed to driving innovation and optimizing tool performance through rigorous testing and the application of cutting-edge technologies.

## Innovations and New Designs

The RD center serves as the cornerstone of ROHIT's design initiatives. Our current portfolio of Milling and Drilling tools is engineered for machining Alloy Steels, Stainless Steel, Titanium, and other specialized alloys, leading the market with the lowest CPC guaranteed for our customers.

## Regrinding Services

At ROHIT, we recognize our responsibility towards environmental sustainability. Our regrinding services not only enable customers to reduce costs but also promote recycling efforts. We provide refurbished tools that maintain original designs and coatings, ensuring performance akin to new ROHIT tools while contributing positively to the environment.



**Chairman**



## Why Choose RIGPL?

- Quality down to last detail
- Expert advice on optimal tool application
- Highest Productivity, Excellent Economic Efficiency
- Specialized solutions to improve your Bottom Line
- Think Tank to make your Cutting Tools Last that bit Longer

## Industry We Support

- Aerospace & Automotive
- Power Generation
- General Engineering
- Die & Mold Industry
- Medical Implants
- Ordnance Manufacturing
- Furniture Manufacturing



# Table of Content

<u>Contents</u>	<u>Pages</u>
Table of Contents-cum-Selection Guide _____	07
Icon Glossary _____	15
Carbide Drills _____	16
Technical Information Carbide Drills _____	49
Carbide Reamers _____	68
Technical Information Carbide Reamers _____	78
Carbide End Mills _____	79
Carbide Customized Tools _____	142
Technical Information Carbide End Mills _____	143
HSS Tool Bits, End Mills & Centre Drills _____	162
HSS Punches _____	183
HSS Customized Tools _____	197
Coating Details _____	201



## Carbide High Performance Drills CTHS series

- High Wear Resistance NOVA coating
- Stable Low Thrust Point Form
- Edge Chamfer to provide longer cutting edge life
- Best suited for Drilling Alloy Steel, SS, Titanium & Ni alloys

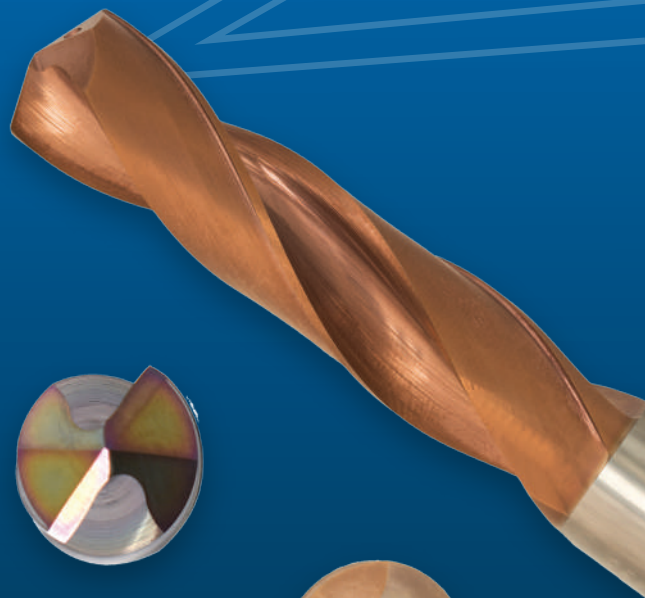

## Carbide High Performance Drills C3AS Series

- Newly Developed High Wear Resistant ALU-IRIS Coated drills for ALU machining
- Edge Honing to provide sturdy drill point



## C3HS Series

- C3HS drills comes with Edge Chamfer to provide longer cutting edge life
- C3HS & C3HL are Best suited for Drilling AS, SUS & Super Alloys



# High Performance Endmills

## 401 & 402 Series

- Developed with Nano-fine grain along with newly Developed Tisinova Coating
- Best Suited for machining upto 65HRc

## 301 & 302 Series

- Developed with Ultra-fine grain along with Nova Coating
- Best Suited for machining upto 55HRc





## Variable Helix Endmills 430, 433 & 434 Series

- Designed for Chatter free machining
- Exceptional performance in machining of Super Alloys

## 330, 333 & 334 Series

- Variable Helix with Ultra-fine grain along with Al-Pro Coating
- Best Suited for machining Alloy Steel and SS

## 311 & 313 Series

- High Helix design with ALU-IRIS Coating for machining AL and AL-Alloys



## CARBIDE DRILLS

Series Group	Series	Image	Diameter Range (in mm)	Stock	# of Flutes	Coating Type	Page Number	Internal coolant
GP-Drills	C1GS		2 ~ 20	Yes	2	TiALN	17	-
	C1GJ		2 ~ 20	Yes	2	None/TiALN	20	-
HP Drills	C3HS		1 ~ 20	Yes	2	NOVA	25	-
	C3HL		1 ~ 20	Yes	2	NOVA	29	-
	CTHS		3 ~ 20	Yes	2	NOVA	32	YES
	CTHL		3 ~ 20	Yes	2	NOVA	36	YES
	CTHM		3 ~ 20	++	2	NOVA	39	YES
Micro Drill	C3MS		0.2 ~ 0.9	Yes	2	NOVA	40	-
HP-Drills for Alu Alloys	C3AS		2 ~ 20	+++	2	ALU-IRIS	41	-
SHP-Drills	C4HT		2 ~ 20	+++	2	PEROX	43	-
Spot Drills	C1N1		6 ~ 20	++	2	-	46	-
	C1N2		6 ~ 20	++	2	-	46	-
Centre Drills	C1CB		BS1 ~ BS7	Yes	2	-	47	-
	C1CD		1.6 ~ 8	Yes	2	-	48	-

## CARBIDE REAMERS

Series Group	Series	Image	Diameter Range (in mm)	Stock	# of Flutes	Coating Type	Page Number	Internal coolant
Reamers	C1RS		3 ~ 16	++	4/6	NONE/TiALN	69	-
	C1RL		3 ~ 16	++	4/6	NONE/TiALN	71	-
	C1RR		3 ~ 16	++	4/6	NONE/TiALN	73	-



# Table of Contents-cum-Selection Guide



Carbon Steels BHN 180 to 225	Alloy Steels BHN 225 to 355	Pre-hardened Steels HRc 40 to 45	Austenitic Stainless Steel	Precipitation Hardened Stainless Steel	Titanium	HighTemp. Alloy	Grey Cast Iron	Ductile Cast Iron	Hardened Steels HRc 45 to 55	High Hardened Steels HRc 55 to 70	Aluminum	Aluminum Alloys	Plastic	Wood / MDF	Plywood/Laminates	Copper / Brass
2 <sup>nd</sup>	2 <sup>nd</sup>		2 <sup>nd</sup>				1 <sup>st</sup>	2 <sup>nd</sup>			1 <sup>st</sup>	2 <sup>nd</sup>				1 <sup>st</sup>
2 <sup>nd</sup>	2 <sup>nd</sup>		2 <sup>nd</sup>				1 <sup>st</sup>	2 <sup>nd</sup>			1 <sup>st</sup>	2 <sup>nd</sup>				1 <sup>st</sup>
1 <sup>st</sup>	1 <sup>st</sup>	1 <sup>st</sup>	1 <sup>st</sup>	2 <sup>nd</sup>	2 <sup>nd</sup>	2 <sup>nd</sup>	1 <sup>st</sup>	1 <sup>st</sup>				1 <sup>st</sup>				
1 <sup>st</sup>	1 <sup>st</sup>	1 <sup>st</sup>	1 <sup>st</sup>	2 <sup>nd</sup>	2 <sup>nd</sup>	2 <sup>nd</sup>	1 <sup>st</sup>	1 <sup>st</sup>				1 <sup>st</sup>				
1 <sup>st</sup>	1 <sup>st</sup>	2 <sup>nd</sup>	1 <sup>st</sup>	1 <sup>st</sup>	1 <sup>st</sup>	1 <sup>st</sup>	1 <sup>st</sup>	1 <sup>st</sup>				2 <sup>nd</sup>				2 <sup>nd</sup>
1 <sup>st</sup>	1 <sup>st</sup>	2 <sup>nd</sup>	1 <sup>st</sup>	1 <sup>st</sup>	1 <sup>st</sup>	1 <sup>st</sup>	1 <sup>st</sup>	1 <sup>st</sup>				2 <sup>nd</sup>				2 <sup>nd</sup>
1 <sup>st</sup>	1 <sup>st</sup>		1 <sup>st</sup>				1 <sup>st</sup>	1 <sup>st</sup>			1 <sup>st</sup>	1 <sup>st</sup>				1 <sup>st</sup>
1 <sup>st</sup>	1 <sup>st</sup>		1 <sup>st</sup>		1 <sup>st</sup>						1 <sup>st</sup>	1 <sup>st</sup>	1 <sup>st</sup>	1 <sup>st</sup>	1 <sup>st</sup>	1 <sup>st</sup>
											1 <sup>st</sup>	1 <sup>st</sup>				
1 <sup>st</sup>	1 <sup>st</sup>	1 <sup>st</sup>	1 <sup>st</sup>	1 <sup>st</sup>	1 <sup>st</sup>	1 <sup>st</sup>	1 <sup>st</sup>	1 <sup>st</sup>								
1 <sup>st</sup>	1 <sup>st</sup>	1 <sup>st</sup>	1 <sup>st</sup>	1 <sup>st</sup>	1 <sup>st</sup>	1 <sup>st</sup>	1 <sup>st</sup>	1 <sup>st</sup>			1 <sup>st</sup>	1 <sup>st</sup>				1 <sup>st</sup>
1 <sup>st</sup>	1 <sup>st</sup>	1 <sup>st</sup>	1 <sup>st</sup>	1 <sup>st</sup>	1 <sup>st</sup>	1 <sup>st</sup>	1 <sup>st</sup>	1 <sup>st</sup>			1 <sup>st</sup>	1 <sup>st</sup>				1 <sup>st</sup>
1 <sup>st</sup>	1 <sup>st</sup>	1 <sup>st</sup>	1 <sup>st</sup>	1 <sup>st</sup>	1 <sup>st</sup>	1 <sup>st</sup>	1 <sup>st</sup>	1 <sup>st</sup>			1 <sup>st</sup>	1 <sup>st</sup>				1 <sup>st</sup>
1 <sup>st</sup>	1 <sup>st</sup>	1 <sup>st</sup>	1 <sup>st</sup>	1 <sup>st</sup>	1 <sup>st</sup>	1 <sup>st</sup>	1 <sup>st</sup>	1 <sup>st</sup>			1 <sup>st</sup>	1 <sup>st</sup>				1 <sup>st</sup>



GP - General Purpose  
HP - High Performance

Delivery Time  
+ 1 Week  
++ 2 Weeks  
+++ 3 Weeks

1<sup>st</sup> 1<sup>st</sup> Choice  
2<sup>nd</sup> 2<sup>nd</sup> choice

Carbon Steels BHN 180 to 225	Alloy Steels BHN 225 to 355	Pre-hardened Steels HRc 40 to 45	Austenitic Stainless Steel	Precipitation Hardened Stainless Steel	Titanium	HighTemp. Alloy	Grey Cast Iron	Ductile Cast Iron	Hardened Steels HRc 45 to 55	High Hardened Steels HRc 55 to 70	Aluminum	Aluminum Alloys	Plastic	Wood / MDF	Plywood/Laminates	Copper / Brass
1 <sup>st</sup>	1 <sup>st</sup>	1 <sup>st</sup>	1 <sup>st</sup>	1 <sup>st</sup>	1 <sup>st</sup>	1 <sup>st</sup>	1 <sup>st</sup>	1 <sup>st</sup>			1 <sup>st</sup>	1 <sup>st</sup>				1 <sup>st</sup>
1 <sup>st</sup>	1 <sup>st</sup>	1 <sup>st</sup>	1 <sup>st</sup>	1 <sup>st</sup>	1 <sup>st</sup>	1 <sup>st</sup>	1 <sup>st</sup>	1 <sup>st</sup>			1 <sup>st</sup>	1 <sup>st</sup>				1 <sup>st</sup>
1 <sup>st</sup>	1 <sup>st</sup>	1 <sup>st</sup>	1 <sup>st</sup>	1 <sup>st</sup>	1 <sup>st</sup>	1 <sup>st</sup>	1 <sup>st</sup>	1 <sup>st</sup>			1 <sup>st</sup>	1 <sup>st</sup>				1 <sup>st</sup>

## CARBIDE END MILLS

Series Group	Series	Image	Dia Range	Stock	# of Flutes	Square End	Ball Nose	Corner Radius	Neck Relief	Coating	Page Number
HP-VHEM*	330		4-20	Yes	4	x		x		AL-PRO	81
	333		6-20	++	5	x		x		AL-PRO	83
	334		3-20	Yes	4	x				AL-PRO	85
HP-SUS*	222		3-20	Yes	4	x				NOVA	88
	321		3-20	Yes	4	x		x		NOVA	89
	322		4-20	Yes	4	x				NOVA	91
HP-VHEM*	430		3-20	Yes	4	x		x		TISINOVA	92
	433		6-16	+++	5	x		x		TISINOVA	94
	434		3-20	Yes	4	x				TISINOVA	95
HP-4X	401		1-20	Yes	4	x				TISINOVA	96
	402		1-12	Yes	2		x		x	TISINOVA	97
	406		2-12	+++	2		x			TISINOVA	98
	423		3-20	Yes	4		x			TISINOVA	99
HP-3X	301		1-20	Yes	4	x	x			NOVA	100
	302		3-16	Yes	4		x		x	NOVA	102
	304		1-12	Yes	2				x	NOVA	103
	305		1-4	Yes	2	x	x		x	NOVA	104
	306		1-4	Yes	2		x	x		NOVA	106
	307		2-12	Yes	2					NOVA	108
	308		6-20	++	6	x				AL-PRO	109
	311		2-20	+++	2	x				ALU-IRIS	110
	313		3-20	+++	3	x				ALU-IRIS	111

# Table of Contents-cum-Selection Guide



























Carbon Steels BHN 180 to 225	Alloy Steels BHN 225 to 355	Pre-hardened Steels HRc 40 to 45	Austenitic Stainless Steel	Precipitation Hardened Stainless Steel	Titanium	HighTemp. Alloy	Grey Cast Iron	Ductile Cast Iron	Hardened Steels HRc 45 to 55	High Hardened Steels HRc 55 to 70	Aluminum	Aluminum Alloys	Plastic	Wood / MDF	Plywood/Laminates	Copper / Brass
1st	1st	1st	1st	1st	2nd	2nd		1st				2nd				
	1st	1st	1st	1st	1st	2nd			2nd							
	1st	1st	1st	2nd	1st	2nd			2nd			2nd				
1st	1st	2nd	1st	2nd			1st	1st	2nd			2nd				
1st	1st	1st	1st	1st	2nd	2nd	1st	1st	2nd	2nd		1st				
1st	1st	1st	1st	1st	2nd	2nd	1st	1st	2nd	2nd		1st				
	2nd	1st	2nd	1st	1st	1st				2nd		2nd				
	2nd	1st	2nd	1st	1st	1st				2nd						
	2nd	1st	2nd	1st	1st	1st			1st	2nd						
									1st	1st						
									1st	1st						
									1st	1st						
	2nd	1st	1st	1st	1st	1st										
		2nd	2nd	2nd					1st	2nd						
	1st	1st	1st	2nd					1st	2nd						
1st		2nd	1st	2nd					1st	2nd		1st				
1st	1st	1st	1st	1st					1st	2nd		1st				
1st	1st	1st	1st	1st					1st	2nd		1st				
1st	1st	1st	1st	1st			1st	1st	1st	2nd	1st	1st				
	1st	1st	1st	1st	1st	2nd				2nd						
											1st	1st				1st
											1st	1st				1st

GP - General Purpose  
HP - High Performance

Delivery Time	+	1 Week
	++	2 Weeks
	+++	3 Weeks

1st	1st Choice
2nd	2nd choice

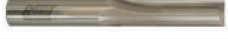
## CARBIDE END MILLS

Series Group	Series	Image	Dia Range	Stock	# of Flutes	Square End	Ball Nose	Corner Radius	Neck Relief	Coating	Page Number
GP-1X	201		3-25	Yes	4	x				TiALN	112
	202		3-20	Yes	4		x			TiALN	114
	205		2-16	Yes	4	x				HYPERLOX	115
	206		1-12	Yes	2		x			HYPERLOX	116
	207		2-10	++	2 & 4	x				TiALN	117
	208		2-10	++	2 & 4		x			TiALN	118
	211		2-20	Yes	2	x				-	119
	212		3-20	Yes	2		x			-	120
	213		3-20	Yes	3	x				-	121
	215		3-20	Yes	2,3,4					TiALN	122
GP-0X	102		3-20	Yes	4		x			TiALN	123
	110		3-20	Yes	4	x				TiALN	124
	121		3-20	Yes	4	x				NOVA	125
	122		1-20	Yes	4	x				NOVA	127
	123		1-20	Yes	2,4		x			NOVA	129
GP-0X (NON-Ferrous)	103		1-12	Yes	2	x				-	131
	104		1-12	Yes	2		x			-	132
	107		3-16	Yes	1	x				-	134
	108		1-4	+	2	x				-	135
	109		1-4	+	2		x			-	136
	112		6-16	+	2	x				-	137
	114		6-16	+	2	x				-	138
	118		3-12	+	2	x				-	139
119		3-12	+	1	x				-	141	

# Table of Contents-cum-Selection Guide



Carbon Steels BHN 180 to 225	Alloy Steels BHN 225 to 355	Pre-hardened Steels HRc 40 to 45	Austenitic Stainless Steel	Precipitation Hardened Stainless Steel	Titanium	HighTemp. Alloy	Grey Cast Iron	Ductile Cast Iron	Hardened Steels HRc 45 to 55	High Hardened Steels HRc 55 to 70	Aluminum	Aluminum Alloys	Plastic	Wood / MDF	Plywood/Laminates	Copper / Brass
1st	2nd	2nd	2nd				1st	2nd			2nd	2nd	2nd	2nd		2nd
1st	2nd	2nd	2nd				1st	2nd			2nd	2nd	2nd	2nd		2nd
	2nd	1st	2nd						1st							
	1st	1st	2nd						1st							
1st	1st	2nd	2nd	2nd	2nd	2nd	1st	1st			1st	1st	1st	1st	1st	1st
1st	1st	2nd	2nd	2nd	2nd	2nd	1st	1st			1st	1st	1st	1st	1st	1st
											1st	1st		2nd		2nd
											1st	1st		2nd		2nd
											1st	1st		2nd		2nd
1st	1st	1st	1st	1st	2nd	2nd	1st	1st			1st	1st		1st		1st
2nd	2nd						2nd	2nd	2nd			2nd				2nd
2nd	2nd						2nd	2nd	2nd			2nd				
2nd	2nd	2nd	2nd				2nd	2nd	2nd			2nd				
2nd	2nd	2nd	2nd				2nd	2nd	2nd			2nd				
2nd	2nd										2nd	2nd	1st	1st	1st	2nd
2nd	2nd										2nd	2nd	1st	1st	1st	2nd
											1st	2nd	1st	1st		1st
2nd							2nd				1st		1st	1st		1st
2nd							2nd				1st		1st	1st		1st
												2nd		1st	1st	
		2nd	1st	2nd										1st	2nd	
1st	1st						1st				1st		1st	1st		2nd



GP - General Purpose  
HP - High Performance

Delivery Time	+	1 Week
	++	2 Weeks
	+++	3 Weeks

1st	1st Choice
2nd	2nd Choice

Description	Page No
GRADE CHART of HSS CUTTING TOOLS	163
HSS Square Tools Bits   (Inch Sizes)	164
HSS Square Tools Bits   (Metric Sizes)	165
HSS Rectangular (Flat) Tools Bits   (Inch Sizes)	166
HSS Rectangular (Flat) Tools Bits   (Metric Sizes)	168
HSS Round Tool Bits   (Inch Sizes)	170
HSS Round Tool Bits   (Metric Sizes)	172
HSS Parting Blades   Cut-Off Blades	175
HSS Parallel Shank End Mills   (Imperial Sizes)	180
HSS Parallel Shank End Mills   (Metric Sizes)	181
HSS Center Drills   Type-A	182
Geometry & Instructions	176

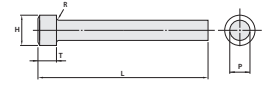
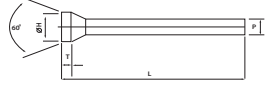
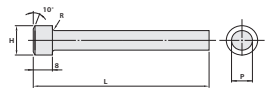
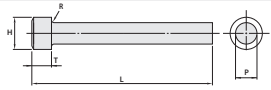
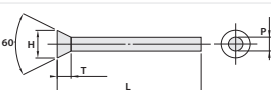
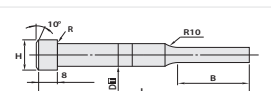
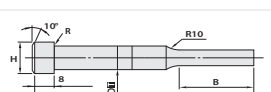
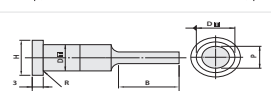
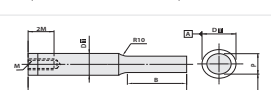
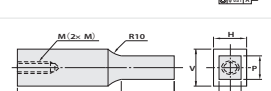

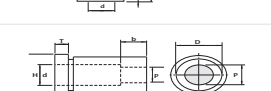
Series	Description	Body/Tip Dia "P" (0.1 mm Increments)	Stock Availability	Drawing	Page Number
<b>Index - HSS Punches</b>					<b>183</b>
P101	HSS Straight Punches	1.1-25	Yes		186
P102	HSS Tapered Head Punches	3.0-12	++		187
P103	HSS Straight Punches For Medium Load	2.1-25	++		188
P104	HSS Straight Punches For Heavy Load	2.1-25	++		189
P105	HSS Mini Straight Punches	1-3	++		190
P106	HSS Shoulder Punches	2-24.9	+++		191
P107	HSS Shoulder Punches For Heavy Load	2-24.9	+++		192
P108	HSS Shoulder Punches Short Type	2-9.9	+++		193
P109	HSS Tapped Punches	2-24.9	Ask for Delivery Time		194
P110	HSS Block Punches		Ask for Delivery Time		195
P112	HSS Straight Button Dies		Ask for Delivery Time		196
P113	HSS Headed Button Dies		Ask for Delivery Time		196

## APPLICATION TYPE



Plunging

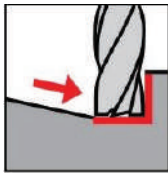

Ramping

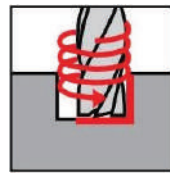

Interpolation

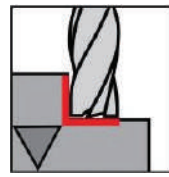

Roughing

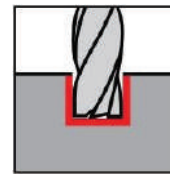

Slotting

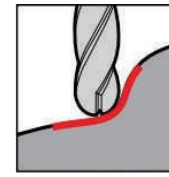

Copy Milling

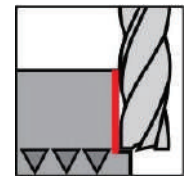

Finishing

## TOOL IDENTIFICATION



Solid Carbide



Coolant Fed



Cutting Edge Length



Drill Point Angle



Helix Angle



Din Specs



Chamfer



Variable Helix 5-Flute



Variable Helix 4-Flute



Number of Flutes



Right Hand Cutting



Shank Type

## CARBIDE GRAIN SIZE



Nano Fine Grain



Ultra Micro Fine Grain



Sub Micro Fine Grain



Micro Fine Grain

## COATING TYPES



TiAlN



HYPERLOX



NOVA



AL-PRO



PEROX



TISINOVA



ALU-IRIS

## WORKPIECE MATERIAL GROUP



Steels



Hardend Steels  
(35-65 HRC)



Stainless Steels



Cast Iron



Special Alloys



Non-Ferrous



# HIGH PERFORMANCE DRILLING

## Features

- Advanced “Active Cut” Geometric Design
- Redefined Critical Cut Zone Characteristics
- High-Efficiency Flute Profile
- Stable Low-Thrust Point Form
- Diameter Range - 2.0mm to 25.0mm, 5/64” to 1”
- Stub (3X), Regular (5X), Long (8X+) and Extra Long (15X+)

## Benefits of ROHIT Drills

- Extended Tool Life
- Elevated Metal Removal Rates (MRR)
- Lower cost Per Hole
- Improved Hole/Part Quality
- Increased Tool Reliability
- Factory Reconditioning Service

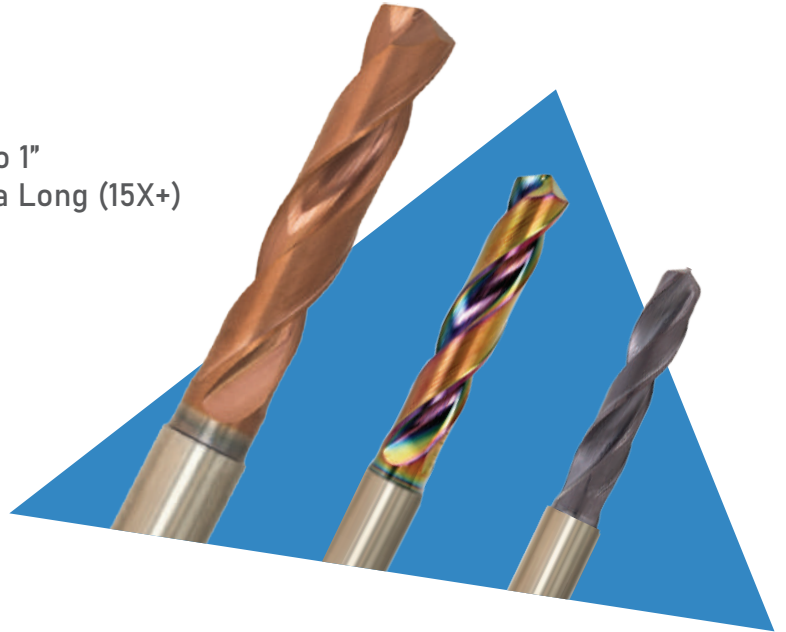

Type	Name	Series	Page No
General Purpose Drills	Stub Series	C1GS	17
	Jobber Series	C1GJ	20
High Performance Drills	Short Series	C3HS	25
	Long Series	C3HL	29
	Coolant Fed Short Drills	CTHS	32
	Coolant Fed Long Drills	CTHL	36
	MQL Drills	CTHM	39
Micro Drills	Micro Drills	C3MS	40
HP-Drills for Alu-Alloys	High Performance Drills for Alu-Alloys	C3AS	41
SHP-Drills	Super High Performance Drills	C4HT	43
Spot Drills	NC-Spotting Drills 90*	C1N1	46
	NC-Spotting Drills 120*	C1N2	46
Centre Drills	Centre Drills BS328	C1CB	47
	Centre Drills DIN333	C1CD	48
Technical Information	Feed and Speed Parameters		51

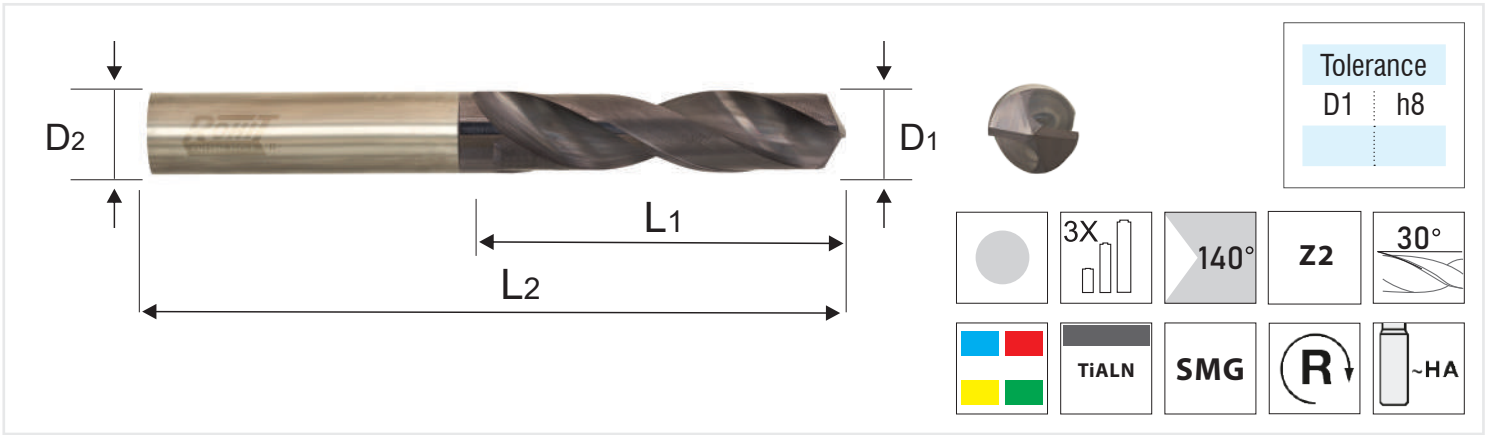

## Features:

- Give Better Life & productivity in comparison to HSS Co drills,
- Suited for Drilling various types of materials like Cast Iron, Non-ferrous metals & Free cutting steel

Item Code TiAlN Coated	Flute Dia(D1)	Flute Len(L1)	Overall Len(L2)	Shank Dia(D2)
CR11GDR004U3	2.0	12	39	2.0
CR11GDR004Y4	2.1	14	39	2.1
CR11GDR004Z2	2.2	14	39	2.2
CR11GDR00503	2.3	14	39	2.3
CR11GDR00511	2.4	14	39	2.4
CR11GDR00529	2.5	14	39	2.5
CR11GDR00545	2.6	20	54	2.6
CR11GDR00552	2.7	20	54	2.7
CR11GDR00560	2.8	20	54	2.8
CR11GDR00586	2.9	20	54	2.9
CR11GDR00594	3.0	20	54	3.0
CR11GDR005C2	3.1	20	54	3.1
CR11GDR005E7	3.2	20	54	3.2
CR11GDR005G3	3.3	20	54	3.3
CR11GDR005J6	3.4	20	54	3.4
CR11GDR005M0	3.5	20	54	3.5
CR11GDR005P3	3.6	22	54	3.6
CR11GDR005R9	3.7	22	54	3.7
CR11GDR005T4	3.8	22	54	3.8
CR11GDR005V0	3.9	22	54	3.9

Item Code TiAlN Coated	Flute Dia(D1)	Flute Len(L1)	Overall Len(L2)	Shank Dia(D2)
CR11GDR005X5	4.0	22	54	4.0
CR11GDR005Z1	4.1	24	63	4.1
CR11GDR00610	4.2	24	63	4.2
CR11GDR00636	4.3	24	63	4.3
CR11GDR00651	4.4	24	63	4.4
CR11GDR00677	4.5	24	63	4.5
CR11GDR006A5	4.6	26	63	4.6
CR11GDR006C1	4.7	26	63	4.7
CR11GDR006E6	4.8	26	63	4.8
CR11GDR006G2	4.9	26	63	4.9
CR11GDR006J5	5.0	26	63	5.0
CR11GDR006L1	5.1	28	63	5.1
CR11GDR006N6	5.2	28	63	5.2
CR11GDR006R8	5.3	28	63	5.3
CR11GDR006U1	5.4	28	63	5.4
CR11GDR006W7	5.5	28	63	5.5
CR11GDR006Y2	5.6	28	63	5.6
CR11GDR00701	5.7	28	63	5.7
CR11GDR00727	5.8	28	63	5.8
CR11GDR00743	5.9	28	63	5.9

Item Code TiAlN Coated	Flute Dia(D1)	Flute Len(L1)	Overall Len(L2)	Shank Dia(D2)
CR11GDR00768	6.0	28	63	6.0
CR11GDR00784	6.1	31	63	6.1
CR11GDR007A4	6.2	31	63	6.2
CR11GDR007D7	6.3	31	63	6.3
CR11GDR007F3	6.4	31	63	6.4
CR11GDR007J4	6.5	31	63	6.5
CR11GDR007L0	6.6	34	63	6.6
CR11GDR007N5	6.7	34	63	6.7
CR11GDR007Q9	6.8	34	63	6.8
CR11GDR007T2	6.9	34	63	6.9
CR11GDR007W6	7.0	34	63	7.0
CR11GDR007Y1	7.1	34	79	7.1
CR11GDR00800	7.2	34	79	7.2
CR11GDR00826	7.3	34	79	7.3
CR11GDR00842	7.4	34	79	7.4
CR11GDR00867	7.5	34	79	7.5
CR11GDR008A3	7.6	37	79	7.6
CR11GDR008C9	7.7	37	79	7.7
CR11GDR008E4	7.8	37	79	7.8
CR11GDR008G0	7.9	37	79	7.9
CR11GDR008J3	8.0	37	79	8.0
CR11GDR008L9	8.1	37	79	8.1
CR11GDR008N4	8.2	37	79	8.2
CR11GDR008R6	8.3	37	79	8.3
CR11GDR008T1	8.4	37	79	8.4
CR11GDR008W5	8.5	37	79	8.5
CR11GDR00909	8.6	40	79	8.6
CR11GDR00933	8.7	40	79	8.7
CR11GDR00958	8.8	40	79	8.8
CR11GDR00982	8.9	40	79	8.9
CR11GDR009A2	9.0	40	79	9.0
CR11GDR009E3	9.1	40	79	9.1
CR11GDR009G9	9.2	40	79	9.2

Item Code TiAlN Coated	Flute Dia(D1)	Flute Len(L1)	Overall Len(L2)	Shank Dia(D2)
CR11GDR009J2	9.3	40	79	9.3
CR11GDR009L8	9.4	40	79	9.4
CR11GDR009N3	9.5	40	79	9.5
CR11GDR009Q7	9.6	42	79	9.6
CR11GDR009S2	9.7	42	79	9.7
CR11GDR009V6	9.8	42	79	9.8
CR11GDR009X1	9.9	42	79	9.9
CR11GDR009Z7	10.0	42	79	10.0
CR11GDR00A19	10.1	42	79	10.1
CR11GDR00A27	10.2	42	79	10.2
CR11GDR00A43	10.3	47	100	10.3
CR11GDR00A50	10.4	47	100	10.4
CR11GDR00A68	10.5	47	100	10.5
CR11GDR00A92	10.6	47	100	10.6
CR11GDR00AA4	10.7	47	100	10.7
CR11GDR00AB2	10.8	47	100	10.8
CR11GDR00AD7	10.9	47	100	10.9
CR11GDR00AE5	11.0	47	100	11.0
CR11GDR00AG1	11.1	47	100	11.1
CR11GDR00AH9	11.2	47	100	11.2
CR11GDR00AJ4	11.3	47	100	11.3
CR11GDR00AK2	11.4	47	100	11.4
CR11GDR00AL0	11.5	47	100	11.5
CR11GDR00AN5	11.6	49	100	11.6
CR11GDR00AP1	11.7	49	100	11.7
CR11GDR00AQ9	11.8	49	100	11.8
CR11GDR00AR7	11.9	49	100	11.9
CR11GDR00AS4	12.0	49	100	12.0
CR11GDR00AU0	12.1	51	102	12.1
CR11GDR00AV8	12.2	51	102	12.2
CR11GDR00AW6	12.3	51	102	12.3
CR11GDR00AX3	12.4	51	102	12.4
CR11GDR00AZ9	12.5	51	102	12.5

Item Code TiALN Coated	Flute Dia(D1)	Flute Len(L1)	Overall Len(L2)	Shank Dia(D2)
CR11GDR00B00	12.6	51	102	12.6
CR11GDR00B18	12.7	51	102	12.7
CR11GDR00B34	12.8	51	102	12.8
CR11GDR00B42	12.9	51	102	12.9
CR11GDR00B59	13.0	51	102	13.0
CR11GDR00B67	13.1	54	107	13.1
CR11GDR00B75	13.2	54	107	13.2
CR11GDR00B83	13.3	54	107	13.3
CR11GDR00B91	13.4	54	107	13.4
CR11GDR00BA3	13.5	54	107	13.5
CR11GDR00BB1	13.6	54	107	13.6
CR11GDR00BC9	13.7	54	107	13.7
CR11GDR00BD6	13.8	54	107	13.8
CR11GDR00BE4	13.9	54	107	13.9
CR11GDR00BF2	14.0	54	107	14.0

Item Code TiALN Coated	Flute Dia(D1)	Flute Len(L1)	Overall Len(L2)	Shank Dia(D2)
CR11GDR00BG0	14.1	56	109	14.1
CR11GDR00BH8	14.2	56	109	14.2
CR11GDR00BJ3	14.3	56	109	14.3
CR11GDR00BK1	14.4	56	109	14.4
CR11GDR00BL9	14.5	56	109	14.5
CR11GDR00BM7	14.6	56	109	14.6
CR11GDR00BN4	14.7	56	109	14.7
CR11GDR00BP0	14.8	56	109	14.8
CR11GDR00BQ8	14.9	56	109	14.9
CR11GDR00BS3	15.0	56	109	15.0
CR11GDR00BT1	16.0	56	109	16.0
CR11GDR00BU9	17.0	56	109	18.0
CR11GDR00BV7	18.0	56	109	18.0
CR11GDR00BW5	19.0	56	109	19.0
CR11GDR00BX2	20.0	56	109	20.0

Carbon Steels BHN 180 to 225	Alloy Steels BHN 225 to 355	Prehardened Steels HRc 40 to 45	Austenitic Stainless Steel	Precipitation Hardened Stainless Steel	Titanium	HighTemp. Alloy	Grey Cast Iron	Ductile Cast Iron	Hardened Steels HRc up to 45	High Hardened Steels HRc 45 to 55	Aluminum	Aluminum Alloys	Plastic	Wood / MDF	Copper/Brass
2 <sup>nd</sup>	2 <sup>nd</sup>		2 <sup>nd</sup>				1 <sup>st</sup>	2 <sup>nd</sup>			1 <sup>st</sup>	2 <sup>nd</sup>			1 <sup>st</sup>

NOTE: FOR FEED & SPEED Rates, go to page no. PG-51

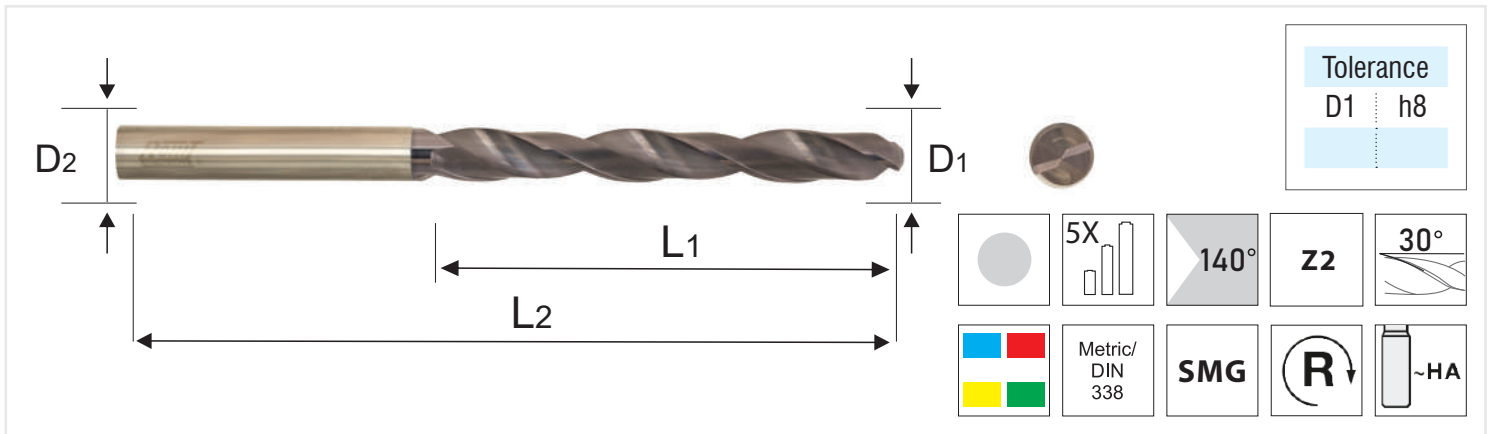

## Features:

- Give Better Life & productivity in comparison to HSS Co drills,
- Suited for Drilling various types of materials like Cast Iron, Non-ferrous metals and Free cutting steel

Item Code (Uncoated)	Ordering Code (TiALN Coated)	Flute Dia(D1)	Flute Len(L1)	Overall Len(L2)	Shank Dia(D2)
CR1XGDR000H7	CR11GDR00P06	2.0	24	61	2.0
CR1XGDR000J2	C1GJ0210-F	2.1	24	61	2.1
CR1XGDR000K0	CR11GDR00T44	2.2	24	61	2.2
CR1XGDR000L8	CR11GDR00P14	2.3	24	61	2.3
CR1XGDR000M6	CR11GDR00T51	2.4	24	61	2.4
CR1XGDR000N3	CR11GDR00099	2.5	24	61	2.5
CR1XGDR000P9	C1GJ0260-F	2.6	33	61	2.6
CR1XGDR000Q7	C1GJ0270-F	2.7	33	61	2.7
CR1XGDR000R5	C1GJ0280-F	2.8	33	61	2.8
CR1XGDR000S2	C1GJ0290-F	2.9	33	61	2.9
CR1XGDR000T0	CR11GDR005A6	3.0	33	61	3.0
CR1XGDR000U8	CR11GDR005D9	3.1	39	70	3.1
CR1XGDR000V6	CR11GDR005F5	3.2	39	70	3.2
CR1XGDR000W4	CR11GDR005H1	3.3	39	70	3.3
CR1XGDR000X1	CR11GDR005K4	3.4	39	70	3.4
CR1XGDR000Y9	CR11GDR005N7	3.5	39	70	3.5
CR1XGDR000Z7	CR11GDR005Q1	3.6	43	75	3.6
CR1XGDR00108	CR11GDR005S6	3.7	43	75	3.7
CR1XGDR00116	CR11GDR005U2	3.8	43	75	3.8
CR1XGDR00124	CR11GDR005W8	3.9	43	75	3.9

Item Code (Uncoated)	Ordering Code (TiAlN Coated)	Flute Dia(D1)	Flute Len(L1)	Overall Len(L2)	Shank Dia(D2)
CR1XGDR00140	CR11GDR005Y3	4.0	43	75	4.0
CR1XGDR00157	CR11GDR00602	4.1	47	80	4.1
CR1XGDR00165	CR11GDR00628	4.2	47	80	4.2
CR1XGDR00173	CR11GDR00644	4.3	47	80	4.3
CR1XGDR00181	CR11GDR00669	4.4	47	80	4.4
CR1XGDR00199	CR11GDR00693	4.5	47	80	4.5
CR1XGDR001B9	CR11GDR006B3	4.6	52	86	4.6
CR1XGDR001C7	CR11GDR006D8	4.7	52	86	4.7
CR1XGDR001D4	CR11GDR006F4	4.8	52	86	4.8
CR1XGDR001E2	CR11GDR006H0	4.9	52	86	4.9
CR1XGDR001G8	CR11GDR006K3	5.0	52	86	5.0
CR1XGDR001H6	CR11GDR006M9	5.1	52	86	5.1
CR1XGDR001J1	CR11GDR006Q0	5.2	52	86	5.2
CR1XGDR001K9	CR11GDR006S5	5.3	57	93	5.3
CR1XGDR001L7	CR11GDR006V9	5.4	57	93	5.4
CR1XGDR001M5	CR11GDR006X4	5.5	57	93	5.5
CR1XGDR001N2	CR11GDR006Z0	5.6	57	93	5.6
CR1XGDR001P8	CR11GDR00719	5.7	57	93	5.7
CR1XGDR001Q6	CR11GDR00735	5.8	57	93	5.8
CR1XGDR001R4	CR11GDR00750	5.9	57	93	5.9
CR1XGDR001S1	CR11GDR00776	6.0	57	93	6.0
CR1XGDR001T9	CR11GDR00792	6.1	63	101	6.1
CR1XGDR001U7	CR11GDR007C0	6.2	63	101	6.2
CR1XGDR001V5	CR11GDR007E5	6.3	63	101	6.3
CR1XGDR001W3	CR11GDR007H9	6.4	63	101	6.4
CR1XGDR001X0	CR11GDR007K2	6.5	63	101	6.5
CR1XGDR001Y8	CR11GDR007M8	6.6	69	109	6.6
CR1XGDR001Z6	CR11GDR007P1	6.7	69	109	6.7
CR1XGDR00207	CR11GDR007S4	6.8	69	109	6.8
CR1XGDR00215	CR11GDR007U0	6.9	69	109	6.9
CR1XGDR00223	CR11GDR007X3	7.0	69	109	7.0
CR1XGDR00231	CR11GDR007Z9	7.1	69	109	7.1
CR1XGDR00249	CR11GDR00818	7.2	69	109	7.2

Item Code (Uncoated)	Ordering Code (TiALN Coated)	Flute Dia(D1)	Flute Len(L1)	Overall Len(L2)	Shank Dia(D2)
CR1XGDR00256	CR11GDR00834	7.3	69	109	7.3
CR1XGDR00264	CR11GDR00859	7.4	69	109	7.4
CR1XGDR00272	CR11GDR00891	7.5	69	109	7.5
CR1XGDR00280	CR11GDR008B1	7.6	75	117	7.6
CR1XGDR00298	CR11GDR008D6	7.7	75	117	7.7
CR1XGDR002A0	CR11GDR008F2	7.8	75	117	7.8
CR1XGDR002B8	CR11GDR008H8	7.9	75	117	7.9
CR1XGDR002C6	CR11GDR008K1	8.0	75	117	8.0
CR1XGDR002E1	CR11GDR008M7	8.1	75	117	8.1
CR1XGDR002F9	CR11GDR008Q8	8.2	75	117	8.2
CR1XGDR002G7	CR11GDR008S3	8.3	75	117	8.3
CR1XGDR002H5	CR11GDR008U9	8.4	75	117	8.4
CR1XGDR002J0	CR11GDR008Z8	8.5	75	117	8.5
CR1XGDR002K8	CR11GDR00917	8.6	81	125	8.6
CR1XGDR002L6	CR11GDR00941	8.7	81	125	8.7
CR1XGDR002M4	CR11GDR00974	8.8	81	125	8.8
CR1XGDR002N1	CR11GDR00990	8.9	81	125	8.9
CR1XGDR002P7	CR11GDR009C8	9.0	81	125	9.0
CR1XGDR002Q5	CR11GDR009F1	9.1	81	125	9.1
CR1XGDR002R3	CR11GDR009H7	9.2	81	125	9.2
CR1XGDR002S0	CR11GDR009K0	9.3	81	125	9.3
CR1XGDR002T8	CR11GDR009M6	9.4	81	125	9.4
CR1XGDR002U6	CR11GDR009P9	9.5	81	125	9.5
CR1XGDR002V4	CR11GDR009R5	9.6	87	133	9.6
CR1XGDR002W2	CR11GDR009T0	9.7	87	133	9.7
CR1XGDR002X9	CR11GDR009W4	9.8	87	133	9.8
CR1XGDR002Y7	CR11GDR009Y9	9.9	87	133	9.9
CR1XGDR002Z5	CR11GDR00A01	10.0	87	133	10.0
CR1XGDR00306	C1GJ1010-F	10.1	87	133	10.1
CR1XGDR00322	CR11GDR00A35	10.2	87	133	10.2
CR1XGDR00330	C1GJ1030-F	10.3	87	133	10.3
CR1XGDR00348	CR11GDR00NQ6	10.4	87	133	10.4
CR1XGDR00355	CR11GDR00A84	10.5	87	133	10.5

Item Code (Uncoated)	Ordering Code (TiAlN Coated)	Flute Dia(D1)	Flute Len(L1)	Overall Len(L2)	Shank Dia(D2)
CR1XGDR00363	C1GJ1060-F	10.6	94	142	10.6
CR1XGDR00371	C1GJ1070-F	10.7	94	142	10.7
CR1XGDR00389	C1GJ1080-F	10.8	94	142	10.8
CR1XGDR00397	C1GJ1090-F	10.9	94	142	10.9
CR1XGDR003A9	CR11GDR00AF3	11.0	94	142	11.0
CR1XGDR003B7	C1GJ1110-F	11.1	94	142	11.1
CR1XGDR003C5	C1GJ1120-F	11.2	94	142	11.2
CR1XGDR003D2	C1GJ1130-F	11.3	94	142	11.3
CR1XGDR003E0	C1GJ1140-F	11.4	94	142	11.4
CR1XGDR003F8	CR11GDR00AM8	11.5	94	142	11.5
CR1XGDR003G6	C1GJ1160-F	11.6	101	151	11.6
CR1XGDR003H4	C1GJ1170-F	11.7	101	151	11.7
CR1XGDR003J9	C1GJ1180-F	11.8	101	151	11.8
CR1XGDR003K7	C1GJ1190-F	11.9	101	151	11.9
CR1XGDR003L5	CR11GDR00AT2	12.0	101	151	12.0
CR1XGDR003M3	C1GJ1210-F	12.1	101	151	12.1
CR1XGDR003N0	C1GJ1220-F	12.2	101	151	12.2
CR1XGDR003P6	C1GJ1230-F	12.3	101	151	12.3
CR1XGDR003Q4	C1GJ1240-F	12.4	101	151	12.4
CR1XGDR003R2	C1GJ1250-F	12.5	101	151	12.5
CR1XGDR003S9	C1GJ1260-F	12.6	101	151	12.6
CR1XGDR003T7	C1GJ1270-F	12.7	101	151	12.7
CR1XGDR003U5	C1GJ1280-F	12.8	101	151	12.8
CR1XGDR003V3	C1GJ1290-F	12.9	101	151	12.9
CR1XGDR003W1	CR11GDR00NU7	13.0	101	151	13.0
CR1XGDR003X8	C1GJ1310-F	13.1	101	151	13.1
CR1XGDR003Y6	C1GJ1320-F	13.2	101	151	13.2
CR1XGDR003Z4	C1GJ1330-F	13.3	101	151	13.3
CR1XGDR00405	C1GJ1340-F	13.4	101	151	13.4
CR1XGDR00413	CR11GDR00TZ0	13.5	101	151	13.5
CR1XGDR00421	C1GJ1360-F	13.6	101	151	13.6
CR1XGDR00439	C1GJ1370-F	13.7	101	151	13.7
CR1XGDR00447	C1GJ1380-F	13.8	101	151	13.8



Item Code (Uncoated)	Ordering Code (TiALN Coated)	Flute Dia(D1)	Flute Len(L1)	Overall Len(L2)	Shank Dia(D2)
CR1XGDR00454	C1GJ1390-F	13.9	101	151	13.9
CR1XGDR00462	CR11GDR00TT3	14.0	101	151	14.0
CR1XGDR00470	C1GJ1410-F	14.1	101	151	14.1
CR1XGDR00488	C1GJ1420-F	14.2	101	151	14.2
CR1XGDR00496	C1GJ1430-F	14.3	101	151	14.3
CR1XGDR004A8	C1GJ1440-F	14.4	101	151	14.4
CR1XGDR004C4	C1GJ1450-F	14.5	101	151	14.5
CR1XGDR004D1	C1GJ1460-F	14.6	101	151	14.6
CR1XGDR004E9	C1GJ1470-F	14.7	101	151	14.7
CR1XGDR004F7	C1GJ1480-F	14.8	101	151	14.8
CR1XGDR004G5	C1GJ1490-F	14.9	101	151	14.9
CR1XGDR004H3	C1GJ1500-F	15.0	101	151	15.0
CR1XGDR004J8	C1GJ1600-F	16.0	101	151	16.0
CR1XGDR004K6	C1GJ1700-F	17.0	101	151	17.0
CR1XGDR004L4	C1GJ1800-F	18.0	101	151	18.0
CR1XGDR004M2	C1GJ1900-F	19.0	101	151	19.0
CR1XGDR004N9	C1GJ2000-F	20.0	101	151	20.0

Carbon Steels BHN 180 to 225	Alloy Steels BHN 225 to 355	Prehardened Steels HRC 40 to 45	Austenitic Stainless Steel	Precipitation Hardened Stainless Steel	Titanium	HighTemp. Alloy	Grey Cast Iron	Ductile Cast Iron	Hardened Steels HRC up to 45	High Hardened Steels HRC 45 to 55	Aluminum	Aluminum Alloys	Plastic	Wood / MDF	Copper/Brass
2 <sup>nd</sup>	2 <sup>nd</sup>		2 <sup>nd</sup>				1 <sup>st</sup>	2 <sup>nd</sup>			1 <sup>st</sup>	2 <sup>nd</sup>			1 <sup>st</sup>

NOTE: FOR FEED & SPEED Rates, go to page no. PG-51

Selection-Guide

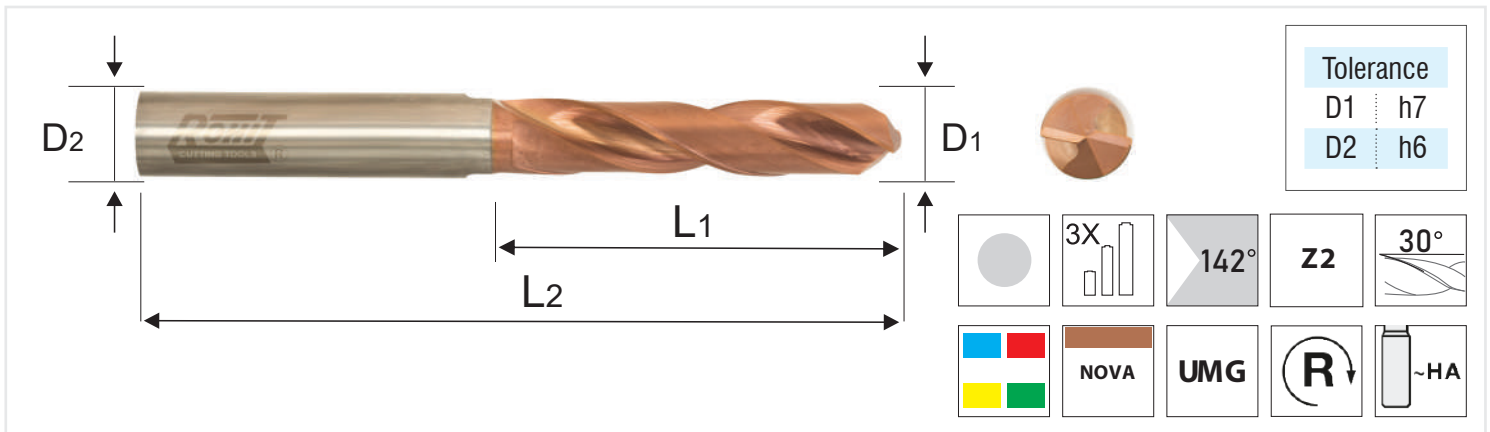

## Features:

- Best Carbide Drill for machining Alloy steel, Cast Iron & SUS material
- Multi-Layer NOVA coating to protect carbide tools at machining temp. up to 1,300°C
- Rapid chip curling to promote chip breakage, improves productivity & achieves unmatched life

Item Code	Flute Dia(D1)	Flute Len(L1)	Overall Len(L2)	Shank Dia(D2)
CR3AHDR00W49	1.0	7	38	3.0
CR3AHDR00W56	1.1	7	38	3.0
CR3AHDR00W64	1.2	8	38	3.0
CR3AHDR00W72	1.3	8	38	3.0
CR3AHDR00W80	1.4	8	38	3.0
CR3AHDR00U66	1.5	8	50	3.0
CR3AHDR00U74	1.6	8	50	3.0
CR3AHDR00U82	1.7	8	50	3.0
CR3AHDR00U90	1.8	10	50	3.0
CR3AHDR00UA2	1.9	11	50	3.0
CR3AHDR00C23	2.0	14	50	4.0
CR3AHDR00C31	2.1	14	50	4.0
CR3AHDR00C49	2.2	14	50	4.0
CR3AHDR00C56	2.3	14	50	4.0
CR3AHDR00C64	2.4	14	50	4.0
CR3AHDR00C72	2.5	14	50	4.0
CR3AHDR00C80	2.6	14	50	4.0
CR3AHDR00C98	2.7	14	50	4.0
CR3AHDR00CA0	2.8	14	50	4.0

Item Code	Flute Dia(D1)	Flute Len(L1)	Overall Len(L2)	Shank Dia(D2)
CR3AHDR00CB8	2.9	14	50	4.0
CR3AHDR00CC6	3.0	20	62	6.0
CR3AHDR00CD3	3.1	20	62	6.0
CR3AHDR00CE1	3.2	20	62	6.0
CR3AHDR00CF9	3.3	20	62	6.0
CR3AHDR00CG7	3.4	20	62	6.0
CR3AHDR00CH5	3.5	20	62	6.0
CR3AHDR00CJ0	3.6	20	62	6.0
CR3AHDR00CK8	3.7	20	62	6.0
CR3AHDR00CL6	3.8	24	62	6.0
CR3AHDR00CM4	3.9	24	62	6.0
CR3AHDR00CN1	4.0	24	62	6.0
CR3AHDR00CP7	4.1	24	62	6.0
CR3AHDR00CQ5	4.2	24	62	6.0
CR3AHDR00CR3	4.3	24	62	6.0
CR3AHDR00CS0	4.4	24	62	6.0
CR3AHDR00CT8	4.5	24	62	6.0
CR3AHDR00CU6	4.6	24	62	6.0
CR3AHDR00CV4	4.7	24	62	6.0

Item Code	Flute Dia(D1)	Flute Len(L1)	Overall Len(L2)	Shank Dia(D2)
CR3AHDR00CW2	4.8	28	62	6.0
CR3AHDR00CX9	4.9	28	62	6.0
CR3AHDR00CY7	5.0	28	62	6.0
CR3AHDR00CZ5	5.1	28	62	6.0
CR3AHDR00D06	5.2	28	62	6.0
CR3AHDR00D14	5.3	28	62	6.0
CR3AHDR00D22	5.4	28	62	6.0
CR3AHDR00D30	5.5	28	62	6.0
CR3AHDR00D48	5.6	28	62	6.0
CR3AHDR00D55	5.7	28	62	6.0
CR3AHDR00D63	5.8	28	62	6.0
CR3AHDR00D71	5.9	28	62	6.0
CR3AHDR00D89	6.0	28	62	6.0
CR3AHDR00D97	6.1	34	75	8.0
CR3AHDR00DA9	6.2	34	75	8.0
CR3AHDR00DB7	6.3	34	75	8.0
CR3AHDR00DC5	6.4	34	75	8.0
CR3AHDR00DD2	6.5	34	75	8.0
CR3AHDR00DE0	6.6	34	75	8.0
CR3AHDR00DF8	6.7	34	75	8.0
CR3AHDR00DG6	6.8	34	75	8.0
CR3AHDR00DH4	6.9	34	75	8.0
CR3AHDR00DJ9	7.0	34	75	8.0
CR3AHDR00DK7	7.1	40	80	8.0
CR3AHDR00DL5	7.2	40	80	8.0
CR3AHDR00DM3	7.3	40	80	8.0
CR3AHDR00DN0	7.4	40	80	8.0
CR3AHDR00DP6	7.5	40	80	8.0
CR3AHDR00DQ4	7.6	40	80	8.0
CR3AHDR00DR2	7.7	40	80	8.0
CR3AHDR00DS9	7.8	40	80	8.0
CR3AHDR00DT7	7.9	40	80	8.0
CR3AHDR00DU5	8.0	40	80	8.0

Item Code	Flute Dia(D1)	Flute Len(L1)	Overall Len(L2)	Shank Dia(D2)
CR3AHDR00P53	8.1	40	80	10.0
CR3AHDR00DV3	8.1	51	100	10.0
CR3AHDR00NV3	8.2	40	80	10.0
CR3AHDR00DW1	8.2	51	100	10.0
CR3AHDR00NP6	8.3	40	75	10.0
CR3AHDR00DX8	8.3	51	100	10.0
CR3AHDR00NH4	8.4	40	75	10.0
CR3AHDR00DY6	8.4	51	100	10.0
CR3AHDR00NJ9	8.5	40	75	10.0
CR3AHDR00DZ4	8.5	51	100	10.0
CR3AHDR00NK7	8.6	40	75	10.0
CR3AHDR00E05	8.6	51	100	10.0
CR3AHDR00NR2	8.7	40	75	10.0
CR3AHDR00E13	8.7	51	100	10.0
CR3AHDR00NZ4	8.8	40	80	10.0
CR3AHDR00E21	8.8	51	100	10.0
CR3AHDR00TU9	8.9	40	80	10.0
CR3AHDR00E39	8.9	51	100	10.0
CR3AHDR00NW1	9.0	40	80	10.0
CR3AHDR00E47	9.0	51	100	10.0
CR3AHDR00P79	9.1	40	80	10.0
CR3AHDR00E54	9.1	51	100	10.0
CR3AHDR00TQ8	9.2	40	80	10.0
CR3AHDR00E62	9.2	51	100	10.0
CR3AHDR00P87	9.3	40	80	10.0
CR3AHDR00E70	9.3	51	100	10.0
CR3AHDR00TV7	9.4	40	80	10.0
CR3AHDR00E88	9.4	51	100	10.0
CR3AHDR00P95	9.5	40	80	10.0
CR3AHDR00E96	9.5	51	100	10.0
CR3AHDR00TW5	9.6	40	80	10.0
CR3AHDR00EA8	9.6	51	100	10.0
CR3AHDR00TX2	9.7	40	80	10.0

Item Code	Flute Dia(D1)	Flute Len(L1)	Overall Len(L2)	Shank Dia(D2)
CR3AHDR00EB6	9.7	51	100	10.0
CR3AHDR00PA7	9.8	40	80	10.0
CR3AHDR00EC4	9.8	51	100	10.0
CR3AHDR00TY0	9.9	40	80	10.0
CR3AHDR00ED1	9.9	51	100	10.0
CR3AHDR00NX8	10.0	40	80	10.0
CR3AHDR00EE9	10.0	51	100	10.0
CR3AHDR00EF7	10.1	55	100	12.0
CR3AHDR00EG5	10.2	55	100	12.0
CR3AHDR00NN0	10.3	40	75	12.0
CR3AHDR00EH3	10.3	55	100	12.0
CR3AHDR00NL5	10.4	40	75	12.0
CR3AHDR00EJ8	10.4	55	100	12.0
CR3AHDR00NM3	10.5	40	75	12.0
CR3AHDR00EK6	10.5	55	100	12.0
CR3AHDR00NS9	10.6	40	75	12.0
CR3AHDR00EL4	10.6	55	100	12.0
CR3AHDR00EM2	10.7	55	100	12.0
CR3AHDR00EN9	10.8	55	100	12.0
CR3AHDR00EP5	10.9	55	100	12.0
CR3AHDR00EQ3	11.0	55	100	12.0
CR3AHDR00ER1	11.1	55	100	12.0
CR3AHDR00ES8	11.2	55	100	12.0
CR3AHDR00ET6	11.3	55	100	12.0
CR3AHDR00EU4	11.4	55	100	12.0
CR3AHDR00EV2	11.5	55	100	12.0
CR3AHDR00EW0	11.6	55	100	12.0
CR3AHDR00EX7	11.7	55	100	12.0
CR3AHDR00EY5	11.8	55	100	12.0
CR3AHDR00EZ3	11.9	55	100	12.0
CR3AHDR00F04	12.0	55	100	12.0
CR3AHDR00PB5	12.2	55	105	14.0
CR3AHDR00U58	12.3	55	105	14.0

Item Code	Flute Dia(D1)	Flute Len(L1)	Overall Len(L2)	Shank Dia(D2)
CR3AHDR00VV5	12.4	55	105	14.0
CR3AHDR00F12	12.5	55	105	14.0
CR3AHDR00VW3	12.6	55	105	14.0
CR3AHDR00P20	12.7	55	105	14.0
CR3AHDR00VG8	12.8	40	80	14.0
CR3AHDR00U33	12.8	55	105	14.0
CR3AHDR00VX0	12.9	55	105	14.0
CR3AHDR00F20	13.0	55	105	14.0
CR3AHDR00P38	13.1	55	105	14.0
CR3AHDR00P46	13.2	55	105	14.0
CR3AHDR00VD4	13.3	55	105	14.0
CR3AHDR00VH6	13.4	55	105	14.0
CR3AHDR00F38	13.5	55	105	14.0
CR3AHDR00W07	13.6	55	105	14.0
CR3AHDR00TS3	13.8	55	105	14.0
CR3AHDR00F46	14.0	55	105	14.0
CR3AHDR00X48	14.1	58	105	16.0
CR3AHDR00U41	14.2	58	105	16.0
CR3AHDR00F53	14.5	58	105	16.0
CR3AHDR00NY6	14.6	40	80	16.0
CR3AHDR00F61	15.0	58	105	16.0
CR3AHDR00WL6	15.2	58	105	16.0
CR3AHDR00F79	15.5	58	105	16.0
CR3AHDR00NT7	15.8	58	105	16.0
CR3AHDR00F87	16.0	58	105	16.0
CR3AHDR00Z04	16.2	58	105	18.0
CR3AHDR00F95	16.5	58	105	18.0
CR3AHDR00WM4	16.7	58	105	18.0
CR3AHDR00FA7	17.0	58	105	18.0
CR3AHDR00FB5	17.5	58	105	18.0
CR3AHDR00FC3	18.0	58	105	18.0
CR3AHDR00FD0	18.5	58	105	20.0
CR3AHDR00FE8	19.0	58	105	20.0

Item Code	Flute Dia(D1)	Flute Len(L1)	Overall Len(L2)	Shank Dia(D2)
CR3AHDR00FF6	19.5	58	105	20.0
CR3AHDR00YZ3	19.7	58	105	20.0

Item Code	Flute Dia(D1)	Flute Len(L1)	Overall Len(L2)	Shank Dia(D2)
CR3AHDR00FG4	20.0	58	105	20.0

Note: Machining Austenitic Stainless Steel (300 series) generally requires Drills with Internal Coolant like our CTHS or CTHL Series.

### Problem with High Performance Carbide Drills usage today!

With everyday rising demand of higher productivity and low cost Auto components; High Performance Solid Carbide Drills are becoming the need of the hour however in this endeavor Industries are facing the problem as to what are the best ways to use Carbide Drills. Many CNC shop floors still face a lot of breakage issues, low performance issues due to wrong usages of there Carbide Drills.

[Read more on rigpl.com/blog](http://rigpl.com/blog)

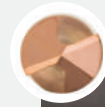

Carbon Steels BHN 180 to 225	Alloy Steels BHN 225 to 355	Prehardened Steels HRc 40 to 45	Austenitic Stainless Steel	Precipitation Hardened Stainless Steel	Titanium	HighTemp. Alloy	Grey Cast Iron	Ductile Cast Iron	Hardened Steels HRc up to 45	High Hardened Steels HRc 45 to 55	Aluminum	Aluminum Alloys	Plastic	Wood / MDF	Copper/Brass
1 <sup>st</sup>	1 <sup>st</sup>	1 <sup>st</sup>	1 <sup>st</sup>	2 <sup>nd</sup>	2 <sup>nd</sup>	2 <sup>nd</sup>	1 <sup>st</sup>	1 <sup>st</sup>							1 <sup>st</sup>

NOTE: FOR FEED & SPEED Rates, go to page no. PG-53

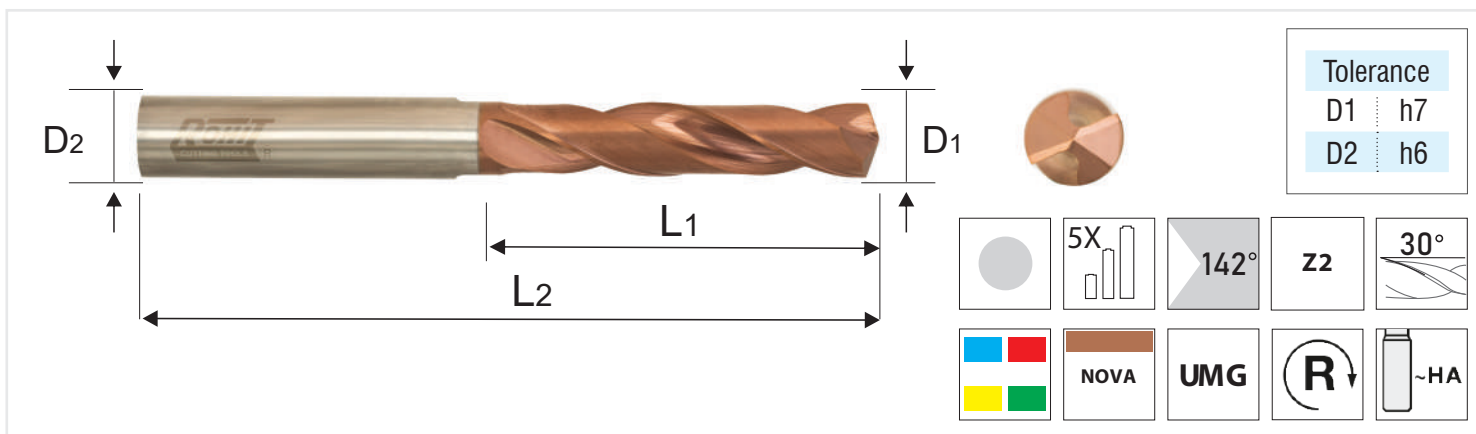

Tolerance	
D1	h7
D2	h6

## Features:

- Best Carbide Drill for machining Alloy steel, Cast Iron & SUS material
- Multi-Layer NOVA coating to protect carbide tools at machining temp. up to 1,300°C
- Rapid chip curling to promote chip breakage, improves productivity & achieves unmatched life
- Suitable for drilling depths from 5 to 8 L/D

Item Code	Flute Dia(D1)	Flute Len(L1)	Overall Len(L2)	Shank Dia(D2)
CR3AHDR00W98	1.0	12	38	3.0
CR3AHDR00WA0	1.1	12	38	3.0
CR3AHDR00WB8	1.2	12	38	3.0
CR3AHDR00WC6	1.3	15	50	3.0
CR3AHDR00WD3	1.4	15	50	3.0
CR3AHDR00UB0	1.5	15	54	3.0
CR3AHDR00UC8	1.6	15	54	3.0
CR3AHDR00UD5	1.7	15	54	3.0
CR3AHDR00UE3	1.8	18	54	3.0
CR3AHDR00UF1	1.9	18	54	3.0
CR3AHDR00FH2	2.0	21	57	4.0
CR3AHDR00FJ7	2.1	21	57	4.0
CR3AHDR00FK5	2.2	21	57	4.0
CR3AHDR00FL3	2.3	21	57	4.0
CR3AHDR00FM1	2.4	21	57	4.0
CR3AHDR00FN8	2.5	21	57	4.0
CR3AHDR00FP4	2.6	21	57	4.0
CR3AHDR00FQ2	2.7	21	57	4.0
CR3AHDR00FR0	2.8	21	57	4.0
CR3AHDR00FS7	2.9	21	57	4.0

Item Code	Flute Dia(D1)	Flute Len(L1)	Overall Len(L2)	Shank Dia(D2)
CR3AHDR00FT5	3.0	28	62	6.0
CR3AHDR00FU3	3.1	28	62	6.0
CR3AHDR00FV1	3.2	28	62	6.0
CR3AHDR00FW9	3.3	28	62	6.0
CR3AHDR00FX6	3.4	28	62	6.0
CR3AHDR00FY4	3.5	28	62	6.0
CR3AHDR00FZ2	3.6	28	62	6.0
CR3AHDR00G03	3.7	28	62	6.0
CR3AHDR00G11	3.8	36	75	6.0
CR3AHDR00G29	3.9	36	75	6.0
CR3AHDR00G37	4.0	36	75	6.0
CR3AHDR00G45	4.1	36	75	6.0
CR3AHDR00G52	4.2	36	75	6.0
CR3AHDR00G60	4.3	36	75	6.0
CR3AHDR00G78	4.4	36	75	6.0
CR3AHDR00G86	4.5	36	75	6.0
CR3AHDR00G94	4.6	36	75	6.0
CR3AHDR00GA6	4.7	36	75	6.0
CR3AHDR00GB4	4.8	42	80	6.0
CR3AHDR00GC2	4.9	42	80	6.0

Item Code	Flute Dia(D1)	Flute Len(L1)	Overall Len(L2)	Shank Dia(D2)
CR3AHDR00GD9	5.0	42	80	6.0
CR3AHDR00GE7	5.1	42	80	6.0
CR3AHDR00GF5	5.2	42	80	6.0
CR3AHDR00GG3	5.3	42	80	6.0
CR3AHDR00GH1	5.4	42	80	6.0
CR3AHDR00GJ6	5.5	42	80	6.0
CR3AHDR00GK4	5.6	42	80	6.0
CR3AHDR00GL2	5.7	42	80	6.0
CR3AHDR00GM0	5.8	42	80	6.0
CR3AHDR00GN7	5.9	42	80	6.0
CR3AHDR00GP3	6.0	42	80	6.0
CR3AHDR00GQ1	6.1	55	100	8.0
CR3AHDR00GR9	6.2	55	100	8.0
CR3AHDR00GS6	6.3	55	100	8.0
CR3AHDR00GT4	6.4	55	100	8.0
CR3AHDR00GU2	6.5	55	100	8.0
CR3AHDR00GV0	6.6	55	100	8.0
CR3AHDR00GW8	6.7	55	100	8.0
CR3AHDR00GX5	6.8	55	100	8.0
CR3AHDR00GY3	6.9	55	100	8.0
CR3AHDR00GZ1	7.0	55	100	8.0
CR3AHDR00H02	7.1	60	105	8.0
CR3AHDR00H10	7.2	60	105	8.0
CR3AHDR00H28	7.3	60	105	8.0
CR3AHDR00H36	7.4	60	105	8.0
CR3AHDR00H44	7.5	60	105	8.0
CR3AHDR00H51	7.6	60	105	8.0
CR3AHDR00H69	7.7	60	105	8.0
CR3AHDR00H77	7.8	60	105	8.0
CR3AHDR00H85	7.9	60	105	8.0
CR3AHDR00H93	8.0	60	105	8.0
CR3AHDR00HA5	8.1	75	125	10.0
CR3AHDR00HB3	8.2	75	125	10.0

Item Code	Flute Dia(D1)	Flute Len(L1)	Overall Len(L2)	Shank Dia(D2)
CR3AHDR00HC1	8.3	75	125	10.0
CR3AHDR00HD8	8.4	75	125	10.0
CR3AHDR00HE6	8.5	75	125	10.0
CR3AHDR00HF4	8.6	75	125	10.0
CR3AHDR00HG2	8.7	75	125	10.0
CR3AHDR00HH0	8.8	75	125	10.0
CR3AHDR00HJ5	8.9	75	125	10.0
CR3AHDR00HK3	9.0	75	125	10.0
CR3AHDR00HL1	9.1	75	125	10.0
CR3AHDR00HM9	9.2	75	125	10.0
CR3AHDR00HN6	9.3	75	125	10.0
CR3AHDR00HP2	9.4	75	125	10.0
CR3AHDR00HQ0	9.5	75	125	10.0
CR3AHDR00HR8	9.6	75	125	10.0
CR3AHDR00HS5	9.7	75	125	10.0
CR3AHDR00HT3	9.8	75	125	10.0
CR3AHDR00HU1	9.9	75	125	10.0
CR3AHDR00HV9	10.0	75	125	10.0
CR3AHDR00HW7	10.1	85	140	12.0
CR3AHDR00HX4	10.2	85	140	12.0
CR3AHDR00HY2	10.3	85	140	12.0
CR3AHDR00HZ0	10.4	85	140	12.0
CR3AHDR00J00	10.5	85	140	12.0
CR3AHDR00J18	10.6	85	140	12.0
CR3AHDR00J26	10.7	85	140	12.0
CR3AHDR00J34	10.8	85	140	12.0
CR3AHDR00J42	10.9	85	140	12.0
CR3AHDR00J59	11.0	85	140	12.0
CR3AHDR00J67	11.1	85	140	12.0
CR3AHDR00J75	11.2	85	140	12.0
CR3AHDR00J83	11.3	85	140	12.0
CR3AHDR00J91	11.4	85	140	12.0
CR3AHDR00JA3	11.5	85	140	12.0

Item Code	Flute Dia(D1)	Flute Len(L1)	Overall Len(L2)	Shank Dia(D2)
CR3AHDR00JB1	11.6	85	140	12.0
CR3AHDR00JC9	11.7	85	140	12.0
CR3AHDR00JD6	11.8	85	140	12.0
CR3AHDR00JE4	11.9	85	140	12.0
CR3AHDR00JF2	12.0	85	140	12.0
CR3AHDR00JG0	12.5	85	140	14.0
CR3AHDR00TR6	12.7	85	140	14.0
CR3AHDR00JH8	13.0	85	140	14.0
CR3AHDR00JJ3	13.5	85	140	14.0
CR3AHDR00WR3	13.6	85	140	14.0
CR3AHDR00JK1	14.0	85	140	14.0
CR3AHDR00JL9	14.5	90	145	16.0
CR3AHDR00JM7	15.0	90	145	16.0
CR3AHDR00JN4	15.5	90	145	16.0
CR3AHDR00WX9	15.7	90	145	16.0

Item Code	Flute Dia(D1)	Flute Len(L1)	Overall Len(L2)	Shank Dia(D2)
CR3AHDR00WY7	15.8	90	145	16.0
CR3AHDR00JP0	16.0	90	145	16.0
CR3AHDR00Z12	16.2	95	150	18.0
CR3AHDR00JQ8	16.5	95	150	18.0
CR3AHDR00JR6	17.0	95	150	18.0
CR3AHDR00JS3	17.5	95	150	18.0
CR3AHDR00WV4	17.7	95	150	18.0
CR3AHDR00JT1	18.0	95	150	18.0
CR3AHDR00JU9	18.5	98	150	20.0
CR3AHDR00WU6	18.6	98	150	20.0
CR3AHDR00WW2	18.7	98	150	20.0
CR3AHDR00JV7	19.0	98	150	20.0
CR3AHDR00JW5	19.5	98	150	20.0
CR3AHDR00WK8	19.7	98	150	20.0
CR3AHDR00JX2	20.0	98	150	20.0

Carbon Steels BHN 180 to 225	Alloy Steels BHN 225 to 355	Prehardened Steels HRC 40 to 45	Austenitic Stainless Steel	Precipitation Hardened Stainless Steel	Titanium	HighTemp. Alloy	Grey Cast Iron	Ductile Cast Iron	Hardened Steels HRC up to 45	High Hardened Steels HRC 45 to 55	Aluminum	Aluminum Alloys	Plastic	Wood / MDF	Copper/Brass
1 <sup>st</sup>	1 <sup>st</sup>	1 <sup>st</sup>	1 <sup>st</sup>	2 <sup>nd</sup>	2 <sup>nd</sup>	2 <sup>nd</sup>	1 <sup>st</sup>	1 <sup>st</sup>							1 <sup>st</sup>

NOTE: FOR FEED & SPEED Rates, go to page no. PG-53

Selection-Guide



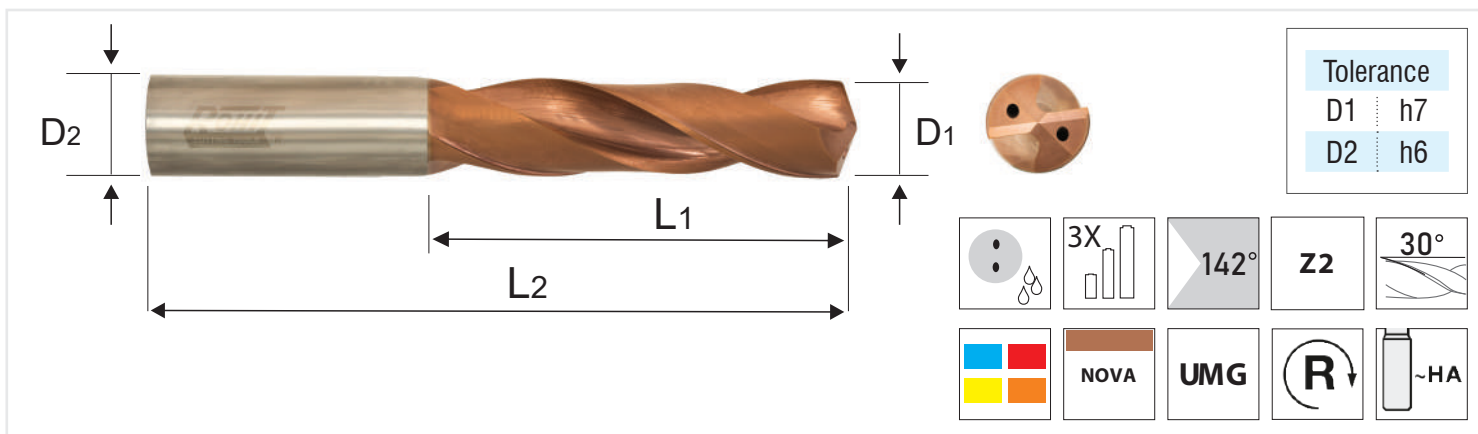

## Features:

- CTHS Coolant Fed Carbide Drills have new chip curling design to enable chip breakage
- At least 15-Bar of Coolant Pressure is recommended for best of use of these Carbide Drills
- CTHS Coolant Fed Carbide Drills are best suited for drilling MS, AS, C.I., and SUS

Item Code	Flute Dia(D1)	Flute Len(L1)	Overall Len(L2)	Shank Dia(D2)
CR3PHDR00UJ7	3.0	20	62	6.0
CR3PHDR00UK5	3.1	20	62	6.0
CR3PHDR00UL3	3.2	20	62	6.0
CR3PHDR00UM1	3.3	20	62	6.0
CR3PHDR00UN8	3.4	20	62	6.0
CR3PHDR00UP4	3.5	20	62	6.0
CR3PHDR00UQ2	3.6	20	62	6.0
CR3PHDR00UR0	3.7	20	62	6.0
CR3PHDR00US7	3.8	24	62	6.0
CR3PHDR00UT5	3.9	24	62	6.0
CR3PHDR00UU3	4.0	24	62	6.0
CR3PHDR00PQ7	4.1	24	62	6.0
CR3PHDR00PR5	4.2	24	62	6.0
CR3PHDR00PS2	4.3	24	62	6.0
CR3PHDR00PT0	4.4	24	62	6.0
CR3PHDR00PU8	4.5	24	62	6.0
CR3PHDR00PV6	4.6	24	62	6.0
CR3PHDR00PW4	4.7	24	62	6.0
CR3PHDR00PX1	4.8	28	62	6.0

Item Code	Flute Dia(D1)	Flute Len(L1)	Overall Len(L2)	Shank Dia(D2)
CR3PHDR00PY9	4.9	28	62	6.0
CR3PHDR00PZ7	5.0	28	62	6.0
CR3PHDR00Q08	5.1	28	62	6.0
CR3PHDR00Q16	5.2	28	62	6.0
CR3PHDR00Q24	5.3	28	62	6.0
CR3PHDR00Q32	5.4	28	62	6.0
CR3PHDR00Q40	5.5	28	62	6.0
CR3PHDR00Q57	5.6	28	62	6.0
CR3PHDR00Q65	5.7	28	62	6.0
CR3PHDR00Q73	5.8	28	62	6.0
CR3PHDR00Q81	5.9	28	62	6.0
CR3PHDR00Q99	6.0	28	62	6.0
CR3PHDR00QA1	6.1	34	75	8.0
CR3PHDR00QB9	6.2	34	75	8.0
CR3PHDR00QC7	6.3	34	75	8.0
CR3PHDR00QD4	6.4	34	75	8.0
CR3PHDR00QE2	6.5	34	75	8.0
CR3PHDR00QF0	6.6	34	75	8.0
CR3PHDR00QG8	6.7	34	75	8.0

Item Code	Flute Dia(D1)	Flute Len(L1)	Overall Len(L2)	Shank Dia(D2)	Item Code	Flute Dia(D1)	Flute Len(L1)	Overall Len(L2)	Shank Dia(D2)
CR3PHDR00QH6	6.8	34	75	8.0	CR3PHDR00R64	9.1	40	80	10.0
CR3PHDR00QJ1	6.9	34	75	8.0	CR3PHDR00RS0	9.1	51	100	10.0
CR3PHDR00QK9	7.0	34	75	8.0	CR3PHDR00R72	9.2	40	80	10.0
CR3PHDR00QL7	7.1	40	80	8.0	CR3PHDR00RT8	9.2	51	100	10.0
CR3PHDR00QM5	7.2	40	80	8.0	CR3PHDR00R80	9.3	40	80	10.0
CR3PHDR00QN2	7.3	40	80	8.0	CR3PHDR00RU6	9.3	51	100	10.0
CR3PHDR00QP8	7.4	40	80	8.0	CR3PHDR00R98	9.4	40	80	10.0
CR3PHDR00QQ6	7.5	40	80	8.0	CR3PHDR00RV4	9.4	51	100	10.0
CR3PHDR00QR4	7.6	40	80	8.0	CR3PHDR00RA0	9.5	40	80	10.0
CR3PHDR00QS1	7.7	40	80	8.0	CR3PHDR00RW2	9.5	51	100	10.0
CR3PHDR00QT9	7.8	40	80	8.0	CR3PHDR00RB8	9.6	40	80	10.0
CR3PHDR00QU7	7.9	40	80	8.0	CR3PHDR00RX9	9.6	51	100	10.0
CR3PHDR00QV5	8.0	40	80	8.0	CR3PHDR00RC6	9.7	40	80	10.0
CR3PHDR00QW3	8.1	40	80	10.0	CR3PHDR00RY7	9.7	51	100	10.0
CR3PHDR00RG7	8.1	51	100	10.0	CR3PHDR00RD3	9.8	40	80	10.0
CR3PHDR00QX0	8.2	40	80	10.0	CR3PHDR00RZ5	9.8	51	100	10.0
CR3PHDR00RH5	8.2	51	100	10.0	CR3PHDR00RE1	9.9	40	80	10.0
CR3PHDR00QY8	8.3	40	80	10.0	CR3PHDR00S06	9.9	51	100	10.0
CR3PHDR00RJ0	8.3	51	100	10.0	CR3PHDR00RF9	10.0	40	80	10.0
CR3PHDR00QZ6	8.4	40	80	10.0	CR3PHDR00S14	10.0	51	100	10.0
CR3PHDR00RK8	8.4	51	100	10.0	CR3PHDR00S22	10.1	55	100	12.0
CR3PHDR00R07	8.5	40	80	10.0	CR3PHDR00S30	10.2	55	100	12.0
CR3PHDR00RL6	8.5	51	100	10.0	CR3PHDR00S48	10.3	55	100	12.0
CR3PHDR00R15	8.6	40	80	10.0	CR3PHDR00S55	10.4	55	100	12.0
CR3PHDR00RM4	8.6	51	100	10.0	CR3PHDR00S63	10.5	55	100	12.0
CR3PHDR00R23	8.7	40	80	10.0	CR3PHDR00S71	10.6	55	100	12.0
CR3PHDR00RN1	8.7	51	100	10.0	CR3PHDR00S89	10.7	55	100	12.0
CR3PHDR00R31	8.8	40	80	10.0	CR3PHDR00S97	10.8	55	100	12.0
CR3PHDR00RP7	8.8	51	100	10.0	CR3PHDR00SA9	10.9	55	100	12.0
CR3PHDR00R49	8.9	40	80	10.0	CR3PHDR00SB7	11.0	55	100	12.0
CR3PHDR00RQ5	8.9	51	100	10.0	CR3PHDR00SC5	11.1	55	100	12.0
CR3PHDR00R56	9.0	40	80	10.0	CR3PHDR00SD2	11.2	55	100	12.0
CR3PHDR00RR3	9.0	51	100	10.0	CR3PHDR00SE0	11.3	55	100	12.0

Item Code	Flute Dia(D1)	Flute Len(L1)	Overall Len(L2)	Shank Dia(D2)	Item Code	Flute Dia(D1)	Flute Len(L1)	Overall Len(L2)	Shank Dia(D2)
CR3PHDR00SF8	11.4	55	100	12.0	CR3PHDR00SS9	14.5	58	105	16.0
CR3PHDR00SG6	11.5	55	100	12.0	CR3PHDR00ST7	15.0	58	105	16.0
CR3PHDR00SH4	11.6	55	100	12.0	CR3PHDR00SU5	15.5	58	105	16.0
CR3PHDR00SJ9	11.7	55	100	12.0	CR3PHDR00SV3	16.0	58	105	16.0
CR3PHDR00SK7	11.8	55	100	12.0	CR3PHDR00SW1	16.5	58	105	18.0
CR3PHDR00SL5	11.9	55	100	12.0	CR3PHDR00VQ1	16.7	58	105	18.0
CR3PHDR00SM3	12.0	55	100	12.0	CR3PHDR00SX8	17.0	58	105	18.0
CR3PHDR00SN0	12.5	55	105	14.0	CR3PHDR00SY6	17.5	58	105	18.0
CR3PHDR00WS5	12.8	55	105	14.0	CR3PHDR00VP3	17.9	58	105	18.0
CR3PHDR00SP6	13.0	55	105	14.0	CR3PHDR00SZ4	18.0	58	105	18.0
CR3PHDR00SQ4	13.5	55	105	14.0	CR3PHDR00T05	18.5	58	105	20.0
CR3PHDR00WH0	13.6	55	105	14.0	CR3PHDR00T13	19.0	58	105	20.0
CR3PHDR00SR2	14.0	55	105	14.0	CR3PHDR00T21	19.5	58	105	20.0
CR3PHDR00VR9	14.2	58	105	16.0	CR3PHDR00T39	20.0	58	105	20.0

Carbon Steels BHN 180 to 225	Alloy Steels BHN 225 to 355	Prehardened Steels HRC 40 to 45	Austenitic Stainless Steel	Precipitation Hardened Stainless Steel	Titanium	HighTemp. Alloy	Grey Cast Iron	Ductile Cast Iron	Hardened Steels HRC up to 45	High Hardened Steels HRC 45 to 55	Aluminum	Aluminum Alloys	Plastic	Wood / MDF	Copper/Brass
1 <sup>st</sup>	1 <sup>st</sup>	1 <sup>st</sup>	1 <sup>st</sup>	1 <sup>st</sup>	1 <sup>st</sup>	1 <sup>st</sup>	1 <sup>st</sup>	1 <sup>st</sup>				1 <sup>st</sup>			1 <sup>st</sup>

NOTE: FOR FEED & SPEED Rates, go to page no. PG-55

**Description: S/C Rohit-3X NOVA Th.Coolant-DRILL**

**FØ:6.6 FL:34 SØ:8 OAL:75 Z=2 SERIES-CTHS**

Work-Piece Image



Industry	Auto Components	
Component	Boss Rotor	
Cutting Conditions	Tool Diameter	6.60 mm coolant fed drill
	Cutting Speed	72 m/min
	RPM	3500
	Feed (mm/tooth)	0.2
	Table Feed (mm/min)	700
	PECKING	6mm
	Radial Cut	None
	Milling Type	Through Hole Application
Coolant	6% Mix Water Soluble	
Material	Forged Steel	
Hardness	280~310BHN	
Machine	Vertical Machining Centre	

Performance

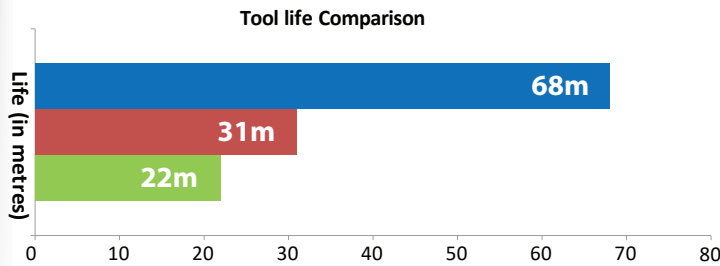

Summary

Drills	Life (in metres)
CTHS	68
Competitor 2	31
Competitor 1	22
Improvement	119%

Result

120% more life than the competition and ~60% Reduction in CPC

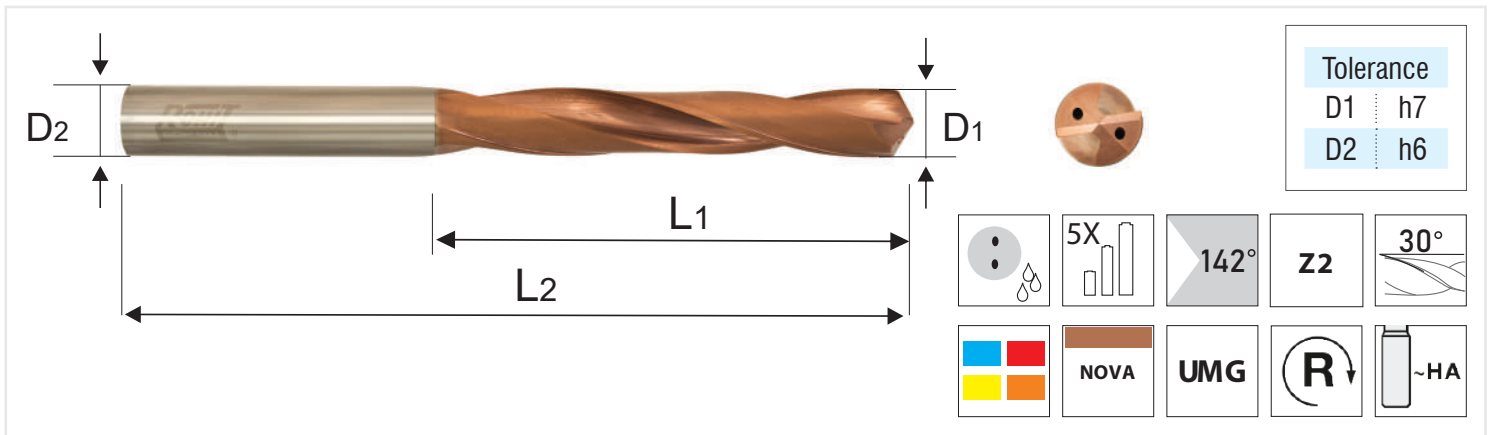

Tolerance	
D1	h7
D2	h6

## Features:

- CTHL Coolant Fed Carbide Drills have new chip curling design to enable chip breakage
- Recommended for drilling depths of greater than 8 L/D
- Best suited for drilling MS, AS, C.I., and SUS

Item Code	Flute Dia(D1)	Flute Len(L1)	Overall Len(L2)	Shank Dia(D2)
CR3AHDR00UV6	3.0	36	75	6.0
CR3AHDR00UW4	3.1	36	75	6.0
CR3AHDR00UX1	3.2	36	75	6.0
CR3AHDR00UY9	3.3	36	75	6.0
CR3AHDR00UZ7	3.4	36	75	6.0
CR3AHDR00V08	3.5	36	75	6.0
CR3AHDR00V16	3.6	36	75	6.0
CR3AHDR00V24	3.7	36	75	6.0
CR3AHDR00V40	3.8	36	75	6.0
CR3AHDR00V32	3.9	36	75	6.0
CR3AHDR00V57	4.0	36	75	6.0
CR3AHDR00X55	4.1	36	75	6.0
CR3AHDR00WE1	4.2	36	75	6.0
CR3AHDR00VB9	4.3	36	75	6.0
CR3AHDR00X63	4.4	36	75	6.0
CR3AHDR00X71	4.5	36	75	6.0
CR3AHDR00WG7	4.6	36	75	6.0
CR3AHDR00X89	4.7	36	75	6.0
CR3AHDR00VA1	4.8	42	80	6.0
CR3AHDR00X97	4.9	42	80	6.0

Item Code	Flute Dia(D1)	Flute Len(L1)	Overall Len(L2)	Shank Dia(D2)
CR3AHDR00VL7	5.0	42	80	6.0
CR3AHDR00VT9	5.1	42	80	6.0
CR3AHDR00XA9	5.2	42	80	6.0
CR3AHDR00VC7	5.3	42	80	6.0
CR3AHDR00WF9	5.4	42	80	6.0
CR3AHDR00WZ5	5.5	42	80	6.0
CR3AHDR00XB7	5.6	42	80	6.0
CR3AHDR00XC5	5.7	42	80	6.0
CR3AHDR00WJ0	5.8	42	80	6.0
CR3AHDR00XD2	5.9	42	80	6.0
CR3AHDR00VS1	6.0	42	80	6.0
CR3AHDR00XE0	6.1	55	100	8.0
CR3AHDR00XF8	6.2	55	100	8.0
CR3AHDR00XG6	6.3	55	100	8.0
CR3AHDR00XH4	6.4	55	100	8.0
CR3AHDR00X06	6.5	55	100	8.0
CR3AHDR00XJ9	6.6	55	100	8.0
CR3AHDR00XK7	6.7	55	100	8.0
CR3AHDR00V73	6.8	55	100	8.0
CR3AHDR00XL5	6.9	55	100	8.0

Item Code	Flute Dia(D1)	Flute Len(L1)	Overall Len(L2)	Shank Dia(D2)
CR3AHDR00V81	7.0	55	100	8.0
CR3AHDR00XM3	7.1	60	105	8.0
CR3AHDR00XN0	7.2	60	105	8.0
CR3AHDR00UH7	7.3	60	105	8.0
CR3AHDR00XP6	7.4	60	105	8.0
CR3AHDR00X14	7.5	60	105	8.0
CR3AHDR00XQ4	7.6	60	105	8.0
CR3AHDR00XR2	7.7	60	105	8.0
CR3AHDR00XS9	7.8	60	105	8.0
CR3AHDR00XT7	7.9	60	105	8.0
CR3AHDR00W31	8.0	60	105	8.0
CR3AHDR00XU5	8.1	75	125	10.0
CR3AHDR00XV3	8.2	75	125	10.0
CR3AHDR00VE2	8.3	75	125	10.0
CR3AHDR00XW1	8.4	75	125	10.0
CR3AHDR00VJ1	8.5	75	125	10.0
CR3AHDR00XX8	8.6	75	125	10.0
CR3AHDR00W15	8.7	75	125	10.0
CR3AHDR00X30	8.8	75	125	10.0
CR3AHDR00XY6	8.9	75	125	10.0
CR3AHDR00UG9	9.0	75	125	10.0
CR3AHDR00XZ4	9.1	75	125	10.0
CR3AHDR00Y05	9.2	75	125	10.0
CR3AHDR00VF0	9.3	75	125	10.0
CR3AHDR00Y13	9.4	75	125	10.0
CR3AHDR00Y21	9.5	75	125	10.0
CR3AHDR00Y39	9.6	75	125	10.0
CR3AHDR00Y47	9.7	75	125	10.0
CR3AHDR00Y54	9.8	75	125	10.0
CR3AHDR00Y62	9.9	75	125	10.0
CR3AHDR00X22	10.0	75	125	10.0
CR3AHDR00Y70	10.1	85	140	12.0
CR3AHDR00Y88	10.2	85	140	12.0
CR3AHDR00VK9	10.3	85	140	12.0

Item Code	Flute Dia(D1)	Flute Len(L1)	Overall Len(L2)	Shank Dia(D2)
CR3AHDR00Y96	10.4	85	140	12.0
CR3AHDR00W23	10.5	85	140	12.0
CR3AHDR00YA8	10.6	85	140	12.0
CR3AHDR00YB6	10.7	85	140	12.0
CR3AHDR00YC4	10.8	85	140	12.0
CR3AHDR00YD1	10.9	85	140	12.0
CR3AHDR00VU7	11.0	85	140	12.0
CR3AHDR00YE9	11.1	85	140	12.0
CR3AHDR00WN1	11.2	85	140	12.0
CR3AHDR00YF7	11.3	85	140	12.0
CR3AHDR00YG5	11.4	85	140	12.0
CR3AHDR00YH3	11.5	85	140	12.0
CR3AHDR00YJ8	11.6	85	140	12.0
CR3AHDR00YK6	11.7	85	140	12.0
CR3AHDR00YL4	11.8	85	140	12.0
CR3AHDR00YM2	11.9	85	140	12.0
CR3AHDR00VY8	12.0	85	140	12.0
CR3AHDR00YN9	12.5	85	140	14.0
CR3AHDR00VZ6	13.0	85	140	14.0
CR3AHDR00YP5	13.5	85	140	14.0
CR3AHDR00WT8	13.6	85	140	14.0
CR3AHDR00VN2	14.0	85	140	14.0
CR3AHDR00WP7	14.5	90	145	16.0
CR3AHDR00YQ3	15.0	90	145	16.0
CR3AHDR00YR1	15.5	90	145	16.0
CR3AHDR00V65	16.0	90	145	16.0
CR3AHDR00VM5	16.5	95	150	18.0
CR3AHDR00YS8	17.0	95	150	18.0
CR3AHDR00YT6	17.5	95	150	18.0
CR3AHDR00YU4	18.0	95	150	18.0
CR3AHDR00YV2	18.5	100	150	20.0
CR3AHDR00YW0	19.0	100	150	20.0
CR3AHDR00YX7	19.5	100	150	20.0
CR3AHDR00YY5	20.0	100	150	20.0



Carbon Steels BHN 180 to 225	Alloy Steels BHN 225 to 355	Prehardened Steels HRc 40 to 45	Austenitic Stainless Steel	Precipitation Hardened Stainless Steel	Titanium	HighTemp. Alloy	Grey Cast Iron	Ductile Cast Iron	Hardened Steels HRc up to 45	High Hardened Steels HRc 45 to 55	Aluminum	Aluminum Alloys	Plastic	Wood / MDF	Copper/Brass
1st	1st	1st	1st	1st	1st	1st	1st	1st				1st			

NOTE: FOR FEED & SPEED Rates, go to page no. PG-55





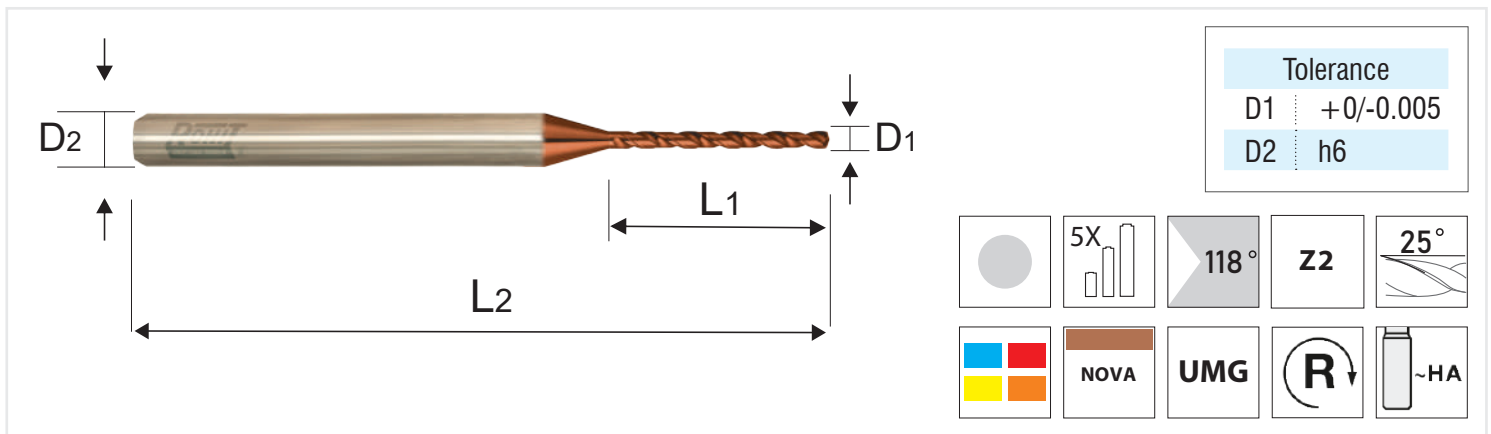

## Features:

- Micro Drills from Dia. 0.2 till 0.9mm
- Multi-Layer NOVA coating to protect carbide drills in drilling at High temp
- Best Suited Micro Drill for machining Alloy steel, Stainless Steel and Aluminium Alloys
- Higher Efficiency with longer tool life

Item Code	Flute Dia(D1)	Flute Len(L1)	Overall Len(L2)	Shank Dia(D2)
C3MS020038-N	0.2	2	38	3.0
C3MS030038-N	0.3	3	38	3.0
C3MS040038-N	0.4	4	38	3.0
C3MS050038-N	0.5	5	38	3.0
C3MS060038-N	0.6	6	38	3.0
C3MS070038-N	0.7	6	38	3.0
C3MS080038-N	0.8	6	38	3.0
C3MS090038-N	0.9	6	38	3.0

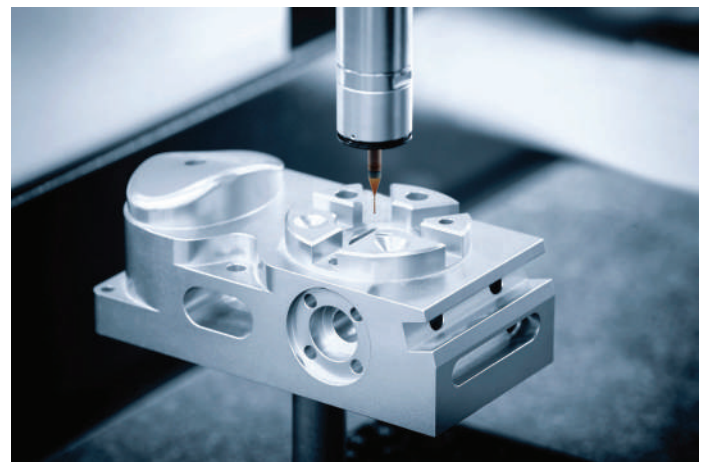

Carbon Steels BHN 180 to 225	Alloy Steels BHN 225 to 355	Prehardened Steels HRC 40 to 45	Austenitic Stainless Steel	Precipitation Hardened Stainless Steel	Titanium	HighTemp. Alloy	Grey Cast Iron	Ductile Cast Iron	Hardened Steels HRC up to 45	High Hardened Steels HRC 45 to 55	Aluminum	Aluminum Alloys	Plastic	Wood / MDF	Copper/Brass
1 <sup>st</sup>	1 <sup>st</sup>	1 <sup>st</sup>	1 <sup>st</sup>		1 <sup>st</sup>		1 <sup>st</sup>	1 <sup>st</sup>	1 <sup>st</sup>		1 <sup>st</sup>				1 <sup>st</sup>

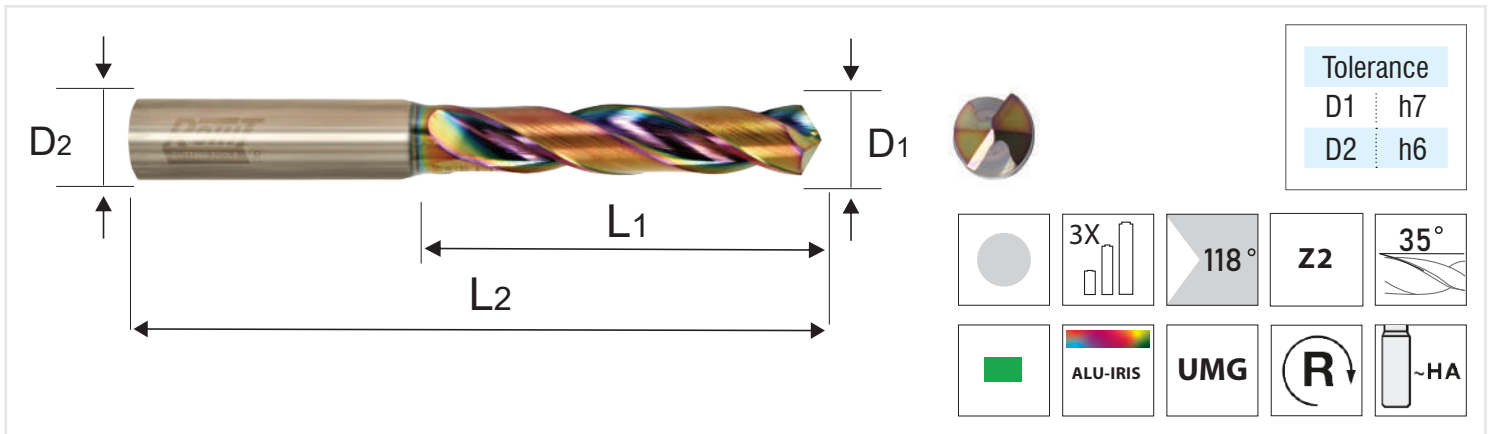

Tolerance	
D1	h7
D2	h6

## Features:

- Highly Effective C3AS-Series for Drilling Aluminium and AL-Alloys
- Super Thin ALU-IRIS coating retains ultra-sharp cutting edges
- Superior smoothness prevents sticking of material in machining Aluminium
- High Rake geometry enables easier chip-evacuation
- Extreme hardness for advanced wear resistance in Al-Alloys with high Silicon content
- Improves productivity & achieves unmatched Life

Ordering Code	Flute Dia(D1)	Flute Len(L1)	Overall Len(L2)	Shank Dia(D2)
C3AS020050040-M	2.0	14	50	4.0
C3AS022050040-M	2.2	14	50	4.0
C3AS025050040-M	2.5	14	50	4.0
C3AS027050040-M	2.7	14	50	4.0
C3AS030062060-M	3.0	20	62	6.0
C3AS032062060-M	3.2	20	62	6.0
C3AS035062060-M	3.5	20	62	6.0
C3AS037062060-M	3.7	20	62	6.0
C3AS040062060-M	4.0	24	62	6.0
C3AS042062060-M	4.2	24	62	6.0
C3AS043062060-M	4.3	24	62	6.0
C3AS045062060-M	4.5	24	62	6.0
C3AS046062060-M	4.6	24	62	6.0
C3AS050062060-M	5.0	28	62	6.0
C3AS051062060-M	5.1	28	62	6.0
C3AS052062060-M	5.2	28	62	6.0
C3AS055062060-M	5.5	28	62	6.0
C3AS058062060-M	5.8	28	62	6.0

Ordering Code	Flute Dia(D1)	Flute Len(L1)	Overall Len(L2)	Shank Dia(D2)
C3AS060062060-M	6.0	28	62	6.0
C3AS063075080-M	6.3	34	75	8.0
C3AS063.5075080-M	6.35	34	75	8.0
C3AS065075080-M	6.5	34	75	8.0
C3AS066075080-M	6.6	34	75	8.0
C3AS068075080-M	6.8	34	75	8.0
C3AS070075080-M	7.0	34	75	8.0
C3AS075080080-M	7.5	40	80	8.0
C3AS079080080-M	7.9	40	80	8.0
C3AS080080080-M	8.0	40	80	8.0
C3AS082100100-M	8.2	51	100	10.0
C3AS085100100-M	8.5	51	100	10.0
C3AS088100100-M	8.8	51	100	10.0
C3AS090080100-M	9.0	40	80	10.0
C3AS090100100-M	9.0	51	100	10.0
C3AS095080100-M	9.5	40	80	10.0
C3AS095100100-M	9.5	51	100	10.0
C3AS100080100-M	10.0	40	80	10.0





Ordering Code	Flute Dia(D1)	Flute Len(L1)	Overall Len(L2)	Shank Dia(D2)
C4HT056062-P	5.6	28	62	6.0
C4HT057062-P	5.7	28	62	6.0
C4HT058062-P	5.8	28	62	6.0
C4HT059062-P	5.9	28	62	6.0
C4HT060062-P	6.0	28	62	6.0
C4HT061075-P	6.1	34	75	8.0
C4HT062075-P	6.2	34	75	8.0
C4HT063075-P	6.3	34	75	8.0
C4HT064075-P	6.4	34	75	8.0
C4HT065075-P	6.5	34	75	8.0
C4HT066075-P	6.6	34	75	8.0
C4HT067075-P	6.7	34	75	8.0
C4HT068075-P	6.8	34	75	8.0
C4HT069075-P	6.9	34	75	8.0
C4HT070075-P	7.0	34	75	8.0
C4HT071080-P	7.1	40	80	8.0
C4HT072080-P	7.2	40	80	8.0
C4HT073080-P	7.3	40	80	8.0
C4HT074080-P	7.4	40	80	8.0
C4HT075080-P	7.5	40	80	8.0
C4HT076080-P	7.6	40	80	8.0
C4HT077080-P	7.7	40	80	8.0
C4HT078080-P	7.8	40	80	8.0
C4HT079080-P	7.9	40	80	8.0
C4HT080080-P	8.0	40	80	8.0
C4HT081080-P	8.1	40	80	10.0
C4HT082080-P	8.2	40	80	10.0
C4HT083080-P	8.3	40	80	10.0
C4HT084080-P	8.4	40	80	10.0
C4HT085080-P	8.5	40	80	10.0
C4HT086080-P	8.6	40	80	10.0
C4HT087080-P	8.7	40	80	10.0
C4HT088080-P	8.8	40	80	10.0

Ordering Code	Flute Dia(D1)	Flute Len(L1)	Overall Len(L2)	Shank Dia(D2)
C4HT089080-P	8.9	40	80	10.0
C4HT090080-P	9.0	40	80	10.0
C4HT091080-P	9.1	40	80	10.0
C4HT092080-P	9.2	40	80	10.0
C4HT093080-P	9.3	40	80	10.0
C4HT094080-P	9.4	40	80	10.0
C4HT095080-P	9.5	40	80	10.0
C4HT096080-P	9.6	40	80	10.0
C4HT097080-P	9.7	40	80	10.0
C4HT098080-P	9.8	40	80	10.0
C4HT099080-P	9.9	40	80	10.0
C4HT100080-P	10.0	40	80	10.0
C4HT081100-P	8.1	60	100	10.0
C4HT082100-P	8.2	60	100	10.0
C4HT083100-P	8.3	60	100	10.0
C4HT084100-P	8.4	60	100	10.0
C4HT085100-P	8.5	60	100	10.0
C4HT086100-P	8.6	60	100	10.0
C4HT087100-P	8.7	60	100	10.0
C4HT088100-P	8.8	60	100	10.0
C4HT089100-P	8.9	60	100	10.0
C4HT090100-P	9.0	60	100	10.0
C4HT091100-P	9.1	60	100	10.0
C4HT092100-P	9.2	60	100	10.0
C4HT093100-P	9.3	60	100	10.0
C4HT094100-P	9.4	60	100	10.0
C4HT095100-P	9.5	60	100	10.0
C4HT096100-P	9.6	60	100	10.0
C4HT097100-P	9.7	60	100	10.0
C4HT098100-P	9.8	60	100	10.0
C4HT099100-P	9.9	60	100	10.0
C4HT100100-P	10.0	60	100	10.0
C4HT101100-P	10.1	60	100	12.0

Ordering Code	Flute Dia(D1)	Flute Len(L1)	Overall Len(L2)	Shank Dia(D2)
C4HT102100-P	10.2	60	100	12.0
C4HT103100-P	10.3	60	100	12.0
C4HT104100-P	10.4	60	100	12.0
C4HT105100-P	10.5	60	100	12.0
C4HT106100-P	10.6	60	100	12.0
C4HT107100-P	10.7	60	100	12.0
C4HT108100-P	10.8	60	100	12.0
C4HT109100-P	10.9	60	100	12.0
C4HT110100-P	11.0	60	100	12.0
C4HT111100-P	11.1	60	100	12.0
C4HT112100-P	11.2	60	100	12.0
C4HT113100-P	11.3	60	100	12.0
C4HT114100-P	11.4	60	100	12.0
C4HT115100-P	11.5	60	100	12.0
C4HT116100-P	11.6	60	100	12.0
C4HT117100-P	11.7	60	100	12.0
C4HT118100-P	11.8	60	100	12.0
C4HT119100-P	11.9	60	100	12.0

Ordering Code	Flute Dia(D1)	Flute Len(L1)	Overall Len(L2)	Shank Dia(D2)
C4HT120100-P	12.0	60	100	12.0
C4HT125105-P	12.5	55	105	14.0
C4HT130105-P	13.0	55	105	14.0
C4HT135105-P	13.5	55	105	14.0
C4HT140105-P	14.0	55	105	14.0
C4HT145105-P	14.5	58	105	16.0
C4HT150105-P	15.0	58	105	16.0
C4HT155105-P	15.5	58	105	16.0
C4HT160105-P	16.0	58	105	16.0
C4HT165105-P	16.5	58	105	18.0
C4HT170105-P	17.0	58	105	18.0
C4HT175105-P	17.5	58	105	18.0
C4HT180105-P	18.0	58	105	18.0
C4HT185105-P	18.5	58	105	20.0
C4HT190105-P	19.0	58	105	20.0
C4HT195105-P	19.5	58	105	20.0
C4HT200105-P	20.0	58	105	20.0

Carbon Steels BHN 180 to 225	Alloy Steels BHN 225 to 355	Prehardened Steels HRC 40 to 45	Austenitic Stainless Steel	Precipitation Hardened Stainless Steel	Titanium	HighTemp. Alloy	Grey Cast Iron	Ductile Cast Iron	Hardened Steels HRC up to 45	High Hardened Steels HRC 45 to 55	Aluminum	Aluminum Alloys	Plastic	Wood / MDF	Copper/Brass
1st	1st	1st	1st	1st	1st	1st	1st	1st	1st						

NOTE: This is Non-stock Item, ask your RIGPL representative for Delivery Period  
FOR FEED & SPEED Rates, go to page no. PG-58

Selection-Guide











**Cutting Lip** - The cutting edges of a two flute drill extending from the chisel edge to the periphery.

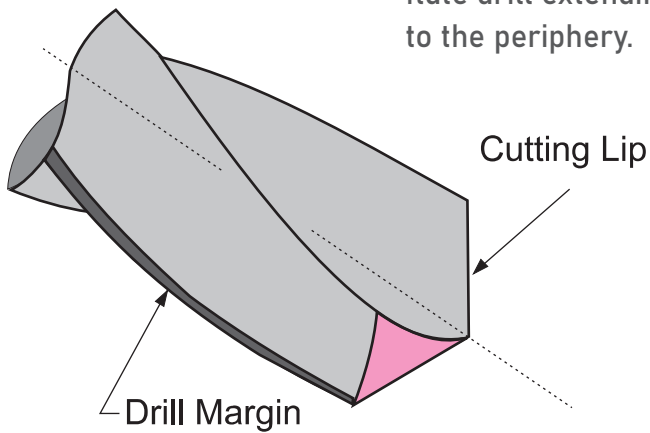

**Margin Width** - Provides a surface to support the drill inside the hole during the drilling operation. RIGPL offers single margin geometries. Margin widths are a balancing act between friction build-up vs. tool support in the drilling operation.

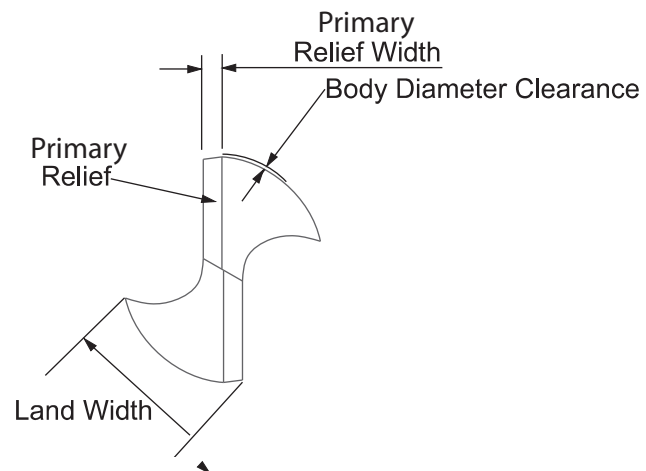

**Land Width** - The amount of material left on the drill per side, from the fluting operation. Larger land widths mean more rigidity, while smaller land widths allow for better chip evacuation.

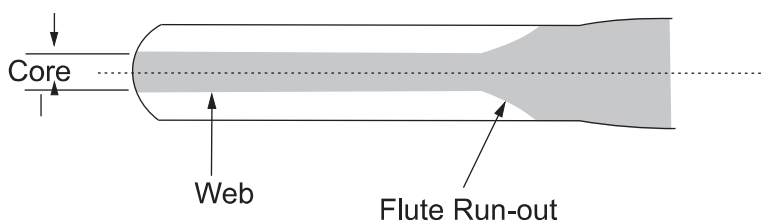

Material	Hardness	Cutting speed (Vc)	FEED per REVOLUTION								
			<3 mm	4 mm	6 mm	8 mm	10 mm	12 mm	16 mm	20 mm	
		m/min	mm / rev								
Alloy Steel	Common Structural Steels	≤100 BHN	60	0.03	0.07	0.12	0.13	0.14	0.18	0.22	0.28
		100-180 BHN	50	0.03	0.07	0.12	0.13	0.14	0.18	0.22	0.28
	Free Cutting Steels	≤24 HRc	60	0.03	0.09	0.14	0.16	0.18	0.22	0.26	0.3
		>24-30 HRc	50	0.03	0.07	0.12	0.13	0.14	0.18	-	-
	Unalloyed Heat-treatable Steels	≤16 HRc	60	0.03	0.07	0.12	0.13	0.14	0.18	0.22	0.28
		16-24 HRc	50	0.03	0.07	0.12	0.13	0.14	0.18	-	-
	Alloyed Heat-treatable Steels	24-30 HRc	40	0.03	0.07	0.12	0.13	0.14	0.18	-	-
		30-38 HRc	-	-	-	-	-	-	-	-	-
	Unalloyed Case-hardened Steels	≤230 BHN	60	0.03	0.07	0.12	0.13	0.14	0.18	0.22	0.28
	Alloyed Case-hardened Steels	24-30 HRc	-	-	-	-	-	-	-	-	-
		30-38 HRc	-	-	-	-	-	-	-	-	-
	Nitriding Steels	24-30 HRc	40	0.03	0.07	0.12	0.13	0.14	0.18	0.22	0.28
		30-38 HRc	-	-	-	-	-	-	-	-	-
	Tool Steels	24-30 HRc	-	-	-	-	-	-	-	-	-
30-38 HRc		-	-	-	-	-	-	-	-	-	
High Speed Steel	14-20 HRc	-	-	-	-	-	-	-	-	-	
Spring Steel	≤330 BHN	-	-	-	-	-	-	-	-	-	
Stainless Steel	Austenitic Stainless Steel	≤24 HRc	20	0.02	0.05	0.09	0.11	0.12	0.14	0.18	0.21
	Austenitic Stainless Steel	≤24 HRc	-	-	-	-	-	-	-	-	-
	Martensitic Stainless Steel	>24 HRc	-	-	-	-	-	-	-	-	-
CAST IRON	Grey Cast Iron	≤230 BHN	60	0.03	0.07	0.12	0.13	0.14	0.18	0.22	0.28
		240-300 BHN	50	0.03	0.07	0.12	0.13	0.14	0.18	0.22	0.28
	Ductile Cast Iron	≤230 BHN	50	0.03	0.07	0.12	0.13	0.14	0.18	0.22	0.28
		240-300 BHN	40	0.03	0.07	0.12	0.13	0.14	0.18	0.22	0.28

Material	Hardness	Cutting speed (Vc)	FEED per REVOLUTION								
			<3 mm	4 mm	6 mm	8 mm	10 mm	12 mm	16 mm	20 mm	
		m/min	mm / rev								
Aluminium And Other Non Ferrous Material	Aluminium Up to 3% Si	≤200 BHN	100	0.04	0.14	0.22	0.24	0.28	0.36	0.4	0.44
	Aluminium Cast Alloys Over 3% Si	≤200 BHN	80	0.04	0.12	0.18	0.2	0.22	0.28	0.36	0.4
	Magnesium Alloys	≤150 BHN	120	0.03	0.09	0.14	0.16	0.18	0.22	0.26	0.3
	Copper, Low-alloyed	≤120 BHN	60	0.03	0.09	0.14	0.16	0.18	0.22	0.26	0.3
	Brass, Short-chipping Long-chipping	≤200 BHN	120	0.03	0.09	0.14	0.16	0.18	0.22	0.26	0.3
	Bronze, Short-chipping	≤200 BHN	80	0.03	0.09	0.14	0.16	0.18	0.22	0.26	0.3
	Bronze, Long-chipping	≤24 HRc	60	0.03	0.07	0.12	0.13	0.14	0.18	0.22	0.28
	Duroplastics	-	40	0.03	0.07	0.12	0.13	0.14	0.18	0.22	0.28
	Thermoplastics	-	30	0.02	0.05	0.09	0.11	0.12	0.14	0.18	0.21
	Reinforced Plastics-kevlar	-	-	-	-	-	-	-	-	-	-
	Reinforced Plastics-GFK/ CF	-	60	0.02	0.05	0.09	0.11	0.12	0.14	0.18	0.21
Super Alloys, Titanium & Nickle Alloys	Titanium	24-30 HRc	-	-	-	-	-	-	-	-	-
		30-38 HRc	-	-	-	-	-	-	-	-	-
	Special Alloys	30-38 HRc	-	-	-	-	-	-	-	-	-

Note: For C1GJ-SERIES REDUCE RPM & FEED by 30% to 35%

- These are just the Starting Parameters, you may vary the Speed and Feed depending upon other machining conditions.

Material	Hardness	Cutting speed (Vc)	FEED per REVOLUTION								
			<3 mm	4 mm	6 mm	8 mm	10 mm	12 mm	16 mm	20 mm	
		m/min	mm / rev								
Alloy Steel	Common Structural Steels	≤100 BHN	80	0.08	0.11	0.13	0.16	0.16	0.2	0.2	0.22
		100-180 BHN	70	0.06	0.08	0.1	0.13	0.13	0.16	0.16	0.18
	Free Cutting Steels	≤24 HRc	90	0.1	0.13	0.16	0.2	0.2	0.25	0.25	0.27
		>24-30 HRc	70	0.08	0.1	0.13	0.16	0.16	0.2	0.2	0.22
	Unalloyed Heat-treatable Steels	≤16 HRc	80	0.08	0.1	0.13	0.16	0.16	0.2	0.2	0.22
		16-24 HRc	70	0.08	0.1	0.13	0.16	0.16	0.2	0.2	0.22
	Alloyed Heat-treatable Steels	24-30 HRc	70	0.08	0.1	0.13	0.16	0.16	0.2	0.2	-
		30-38 HRc	70	0.06	0.08	0.1	0.13	0.13	0.16	0.16	-
	Unalloyed Case-hardened Steels	≤230 BHN	80	0.1	0.13	0.16	0.2	0.2	0.25	0.25	-
	Alloyed Case-hardened Steels	24-30 HRc	80	0.08	0.1	0.13	0.16	0.16	0.2	0.2	-
		30-38 HRc	60	0.05	0.06	0.08	0.1	0.1	0.13	0.13	-
	Nitriding Steels	24-30 HRc	70	0.06	0.08	0.1	0.13	0.13	0.16	0.16	-
		30-38 HRc	60	0.05	0.06	0.08	0.1	0.1	0.13	0.13	-
	Tool Steels	24-30 HRc	40	0.06	0.08	0.1	0.13	0.13	0.16	0.16	-
30-38 HRc		40	0.05	0.06	0.08	0.1	0.1	0.13	0.13	-	
High Speed Steel	14-20 HRc	30	0.04	0.05	0.06	0.08	0.08	0.1	0.1	-	
Spring Steel	≤330 BHN	30	0.03	0.04	0.05	0.06	0.06	0.08	0.08	-	
Stainless Steel	Austenitic Stainless Steel	≤24 HRc	40	0.04	0.06	0.06	0.08	0.08	0.1	0.1	-
	Austenitic Stainless Steel	≤24 HRc	30	0.04	0.06	0.06	0.08	0.08	0.1	0.1	-
	Martensitic Stainless Steel	>24 HRc	30	0.03	0.05	0.05	0.06	0.06	0.08	0.08	-
CAST IRON	Grey Cast Iron	≤230 BHN	130	0.1	0.14	0.16	0.2	0.2	0.25	0.25	0.28
		240-300 BHN	100	0.1	0.14	0.16	0.2	0.2	0.25	0.25	-
	Ductile Cast Iron	≤230 BHN	100	0.08	0.1	0.13	0.16	0.16	0.2	0.2	0.22
		240-300 BHN	80	0.08	0.1	0.13	0.16	0.16	0.2	0.2	-
	Chilled Cast Iron	≤350 BHN	30	0.03	0.05	0.05	0.06	0.06	0.08	0.08	-

Material	Hardness	Cutting speed (Vc)	FEED per REVOLUTION								
			<3 mm	4 mm	6 mm	8 mm	10 mm	12 mm	16 mm	20 mm	
		m/min	mm / rev								
Aluminium And Other Non Ferrous Material	Aluminium and Al-alloys	≤120 BHN	160	0.13	0.2	0.2	0.25	0.25	0.31	0.31	0.33
	Al Wrought Alloys	≤150 BHN	160	0.13	0.2	0.2	0.25	0.25	0.31	0.31	0.33
	Al Cast Alloys ≤ 10 %Si	≤200 BHN	140	0.1	0.16	0.16	0.2	0.2	0.25	0.25	-
	Al Cast Alloy > 10 %Si	≤200 BHN	110	0.1	0.16	0.16	0.2	0.2	0.25	0.25	-
	Magnesiumalloys	≤150 BHN	160	0.1	0.16	0.16	0.2	0.2	0.25	0.25	-
	Copper, Low-alloyed	≤120 BHN	70	0.08	0.08	0.08	0.13	0.13	0.16	0.16	-
	Brass, Short-chipping	≤200 BHN	170	0.1	0.16	0.16	0.2	0.2	0.25	0.25	-
	Brass, Long-chipping	≤200 BHN	110	0.08	0.13	0.13	0.16	0.16	0.2	0.2	-
	Bronze, Short-chipping	≤200 BHN	70	0.08	0.08	0.08	0.13	0.13	0.16	0.16	-
	Bronze, Short-chipping	>200-260 BHN	70	0.06	0.06	0.06	0.1	0.1	0.13	0.13	-
	Bronze, Long-chipping	≤24 HRc	50	0.06	0.06	0.06	0.1	0.1	0.13	0.13	-
	Bronze, Long-chipping	>24-30 HRc	40	0.06	0.06	0.06	0.1	0.1	0.13	0.13	-
	Duroplastics	-	-	-	-	-	-	-	-	-	-
	Thermoplastics	-	-	-	-	-	-	-	-	-	-
	Reinforced Plastics-kevlar	-	-	-	-	-	-	-	-	-	-
	Reinforced Plastics -GFK/ CFK	-	-	-	-	-	-	-	-	-	-
Super Alloys, Titanium & Nickle Alloys	Titanium	24-30 HRc	30	0.04	0.04	0.06	0.08	0.08	0.1	-	-
		30-38 HRc	30	0.03	0.03	0.05	0.06	0.06	0.08	-	-
	Special Alloys	30-38 HRc	20	0.04	0.04	0.06	0.08	0.08	0.1	-	-
HARDENED STEEL	Hardened Steel (<40 HRc)	<40 HRc	20	0.03	0.03	0.04	0.05	0.05	0.06	-	-

NOTE: FOR C3HL-SERIES REDUCE RPM & FEED BY 20% to 25%

• These are just the Starting Parameters, you may vary the Speed and Feed depending upon other machining conditions.

Material	Hardness	Cutting speed (Vc)	FEED per REVOLUTION								
			<3 mm	4 mm	6 mm	8 mm	10 mm	12 mm	16 mm	20 mm	
		m/min	mm / rev								
Alloy Steel	Common Structural Steels	≤100 BHN	90	0.1	0.15	0.15	0.19	0.19	0.24	0.24	0.27
		100-180 BHN	80	0.08	0.12	0.12	0.15	0.15	0.19	0.19	0.21
	Free Cutting Steels	≤24 HRc	110	0.12	0.19	0.19	0.24	0.24	0.3	0.3	0.34
		>24-30 HRc	90	0.12	0.19	0.19	0.24	0.24	0.3	0.3	0.34
	Unalloyed Heat-treatable Steels	≤16 HRc	80	0.12	0.19	0.19	0.24	0.24	0.3	0.3	0.34
		16-24 HRc	80	0.1	0.15	0.15	0.19	0.19	0.24	0.24	0.27
	Alloyed Heat-treatable Steels	24-30 HRc	80	0.1	0.15	0.15	0.19	0.19	0.24	0.24	0.27
		30-38 HRc	70	0.1	0.15	0.15	0.19	0.19	0.24	0.24	0.27
	Unalloyed Case-hardened Steels	≤230 BHN	90	0.12	0.19	0.19	0.24	0.24	0.3	0.3	0.34
	Alloyed Case-hardened Steels	24-30 HRc	80	0.1	0.15	0.15	0.19	0.19	0.24	0.24	0.27
		30-38 HRc	60	0.06	0.1	0.1	0.12	0.12	0.15	0.15	0.17
	Nitriding Steels	24-30 HRc	70	0.1	0.15	0.15	0.19	0.19	0.24	0.24	0.27
		30-38 HRc	70	0.06	0.1	0.1	0.12	0.12	0.15	0.15	0.17
	Tool Steels	24-30 HRc	50	0.08	0.12	0.12	0.15	0.15	0.19	0.19	0.21
30-38 HRc		40	0.06	0.1	0.1	0.12	0.12	0.15	0.15	0.17	
High Speed Steel	14-20 HRc	40	0.05	0.08	0.08	0.1	0.1	0.12	0.12	0.14	
Spring Steel	≤330 BHN	40	0.04	0.06	0.06	0.08	0.08	0.1	0.1	0.11	
Stainless Steel	Austenitic Stainless Steel	≤24 HRc	40	0.06	0.1	0.1	0.12	0.12	0.15	0.15	0.17
	Austenitic Stainless Steel	≤24 HRc	40	0.06	0.1	0.1	0.12	0.12	0.15	0.15	0.17
	Martensitic Stainless Steel	>24 HRc	40	0.05	0.08	0.08	0.1	0.1	0.12	0.12	0.14
CAST IRON	Grey Cast Iron	≤230 BHN	130	0.15	0.24	0.24	0.3	0.3	0.37	0.37	0.4
		240-300 BHN	100	0.15	0.24	0.24	0.3	0.3	0.37	0.37	0.4
	Ductile Cast Iron	≤230 BHN	90	0.15	0.24	0.24	0.3	0.3	0.37	0.37	0.4
		240-300 BHN	80	0.12	0.19	0.19	0.24	0.24	0.3	0.3	0.34
	Chilled Cast Iron	≤350 BHN	30	0.04	0.06	0.06	0.08	0.08	0.1	0.1	0.11



Material	Hardness	Cutting speed (Vc)	FEED per REVOLUTION								
			<3 mm	4 mm	6 mm	8 mm	10 mm	12 mm	16 mm	20 mm	
		m/min	mm / rev								
Aluminium And Other Non Ferrous Material	Aluminium and Al-alloys	≤120 BHN	190	0.15	0.24	0.24	0.3	0.3	0.37	0.37	0.4
	Al Wrought Alloys	≤150 BHN	190	0.15	0.24	0.24	0.3	0.3	0.37	0.37	0.4
	Al Cast Alloys ≤ 10 %Si	≤200 BHN	160	0.15	0.24	0.24	0.3	0.3	0.37	0.37	0.4
	Al Cast Alloy > 10 %Si	≤200 BHN	140	0.15	0.24	0.24	0.3	0.3	0.37	0.37	0.4
	Magnesiumalloys	≤150 BHN	170	0.12	0.19	0.19	0.24	0.24	0.3	0.3	0.34
	Copper, Low-alloyed	≤120 BHN	80	0.1	0.15	0.15	0.19	0.19	0.24	0.24	0.27
	Brass, Short-chipping	≤200 BHN	200	0.12	0.19	0.19	0.24	0.24	0.3	0.3	0.34
	Brass, Long-chipping	≤200 BHN	140	0.1	0.15	0.15	0.19	0.19	0.24	0.24	0.27
	Bronze, Short-chipping	≤200 BHN	80	0.1	0.15	0.15	0.19	0.19	0.24	0.24	0.27
	Bronze, Short-chipping	>200-260 BHN	70	0.08	0.12	0.12	0.15	0.15	0.19	0.19	0.21
	Bronze, Long-chipping	≤24 HRc	60	0.08	0.12	0.12	0.15	0.15	0.19	0.19	0.21
	Bronze, Long-chipping	>24-30 HRc	50	0.08	0.12	0.12	0.15	0.15	0.19	0.19	0.21
	Duroplastics	-	-	-	-	-	-	-	-	-	-
	Thermoplastics	-	-	-	-	-	-	-	-	-	-
	Reinforced Plastics-kevlar	-	-	-	-	-	-	-	-	-	-
	Reinforced Plastics -GFK/ CFK	-	-	-	-	-	-	-	-	-	-
Super Alloys, Titanium & Nickle Alloys	Titanium	24-30 HRc	30	0.05	0.08	0.08	0.1	0.1	0.12	0.12	0.14
		30-38 HRc	30	0.05	0.08	0.08	0.1	0.1	0.12	0.12	0.14
	Special Alloys	30-38 HRC	30	0.05	0.08	0.08	0.1	0.1	0.12	0.12	0.14
HARDENED STEEL	Hardened Steel (<40 HRc)	<40 HRc	30	0.03	0.05	0.05	0.06	0.06	0.08	0.08	0.08

NOTE: FOR CTHL-SERIES REDUCE RPM & FEED BY 20% to 25%

• These are just the Starting Parameters, you may vary the Speed and Feed depending upon other machining conditions.

L/D Ratio	Reduce Feed	Reduce RPM
3XD	100%	100%
5XD	80%	85%
8XD	60%	75%
>8XD	50%	60%

**Important Note:**

- For all deep hole drilling above 8 L/D guide holes are recommended
- Deep hole drills are prone to breakage without guide holes
- Minimum of 800+psi coolant pressure recommended

**FOR MQL DRILLS or DEEP HOLE DRILLS**

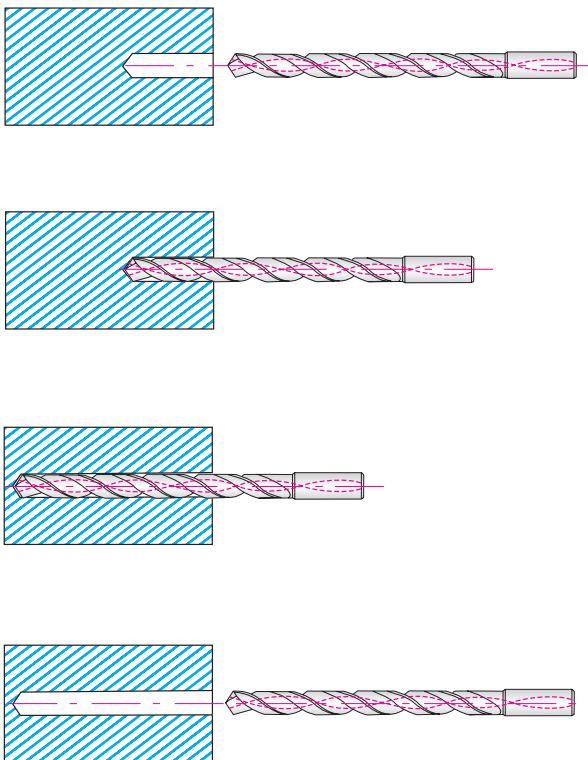

1. Guide Drilling should be done as Diameter+0.1mm between 3xD and 5xD depth.
2. For Main Drilling, proceed with low RPM at Guide Drilling segment. (RPM 300, FEED 400mm/min)
3. Just before the end of Guide Drilling segment, reduce feed to zero and increase the RPM according to Recommended Cutting Condition chart (See above).
4. After then, proceed main drilling by increasing feed without step drilling.
5. When coming out from Guide Drilling start point after drilling, RPM should be reduced as 300 and feed should be 1000 mm/min.
6. When coming out from Guide Drilling segment to the outside, the feed should be decreased as 50%.

Material	Hardness	Cutting speed (Vc)	FEED per REVOLUTION								
			<3 mm	4 mm	6 mm	8 mm	10 mm	12 mm	16 mm	20 mm	
		m/min	mm / rev								
Alloy Steel	Common Structural Steels	≤100 BHN	110	0.13	0.13	0.2	0.25	0.25	0.33	0.33	-
		100-180 BHN	90	0.1	0.1	0.16	0.2	0.2	0.25	0.25	-
	Free Cutting Steels	≤24 HRc	120	0.16	0.16	0.25	0.33	0.33	0.41	0.41	-
		>24-30 HRc	90	0.13	0.13	0.2	0.25	0.25	0.33	0.33	-
	Unalloyed Heat-Treatable Steels	≤16 HRc	100	0.13	0.13	0.2	0.25	0.25	0.33	0.33	-
		16-24 HRc	90	0.13	0.13	0.2	0.25	0.25	0.33	0.33	-
	Alloyed Heat-Treatable Steels	24-30 HRc	90	0.13	0.13	0.2	0.25	0.25	0.33	0.33	-
		30-38 HRc	90	0.1	0.1	0.16	0.2	0.2	0.25	0.25	-
	Unalloyed Case-Hardened Steels	≤230 BHN	110	0.16	0.16	0.25	0.33	0.33	0.41	0.41	-
	Alloyed Case-Hardened Steels	24-30 HRc	100	0.13	0.13	0.2	0.25	0.25	0.33	0.33	-
		30-38 HRc	70	0.08	0.08	0.13	0.16	0.16	0.2	0.2	-
	Nitriding Steels	24-30 HRc	90	0.1	0.1	0.16	0.2	0.2	0.25	0.25	-
		30-38 HRc	80	0.08	0.08	0.13	0.16	0.16	0.2	0.2	-
	Tool Steels	24-30 HRc	60	0.1	0.1	0.16	0.2	0.2	0.25	0.25	-
30-38 HRc		50	0.08	0.08	0.13	0.16	0.16	0.2	0.2	-	
High Speed Steel	14-20 HRc	40	0.06	0.06	0.1	0.13	0.13	0.16	0.16	-	
Spring Steel	≤330 BHN	40	0.05	0.05	0.08	0.1	0.1	0.13	0.13	-	
Stainless Steel	Austentic Stainless Steel	≤24 HRc	50	0.06	0.06	0.1	0.13	0.13	0.16	0.16	-
	Austentic Stainless Steel	≤24 HRc	40	0.06	0.06	0.1	0.13	0.13	0.16	0.16	-
	Martensitic Stainless Steel	>24 HRc	40	0.05	0.05	0.08	0.1	0.1	0.13	0.13	-
Cast Iron	Grey Cast Iron	≤230 BHN	170	0.16	0.16	0.25	0.33	0.33	0.41	0.41	-
		240-300 BHN	130	0.16	0.16	0.25	0.33	0.33	0.41	0.41	-
	Ductile Cast Iron	≤230 BHN	130	0.13	0.13	0.2	0.25	0.25	0.33	0.33	-
		240-300 BHN	100	0.13	0.13	0.2	0.25	0.25	0.33	0.33	-
Chilled Cast Iron	≤350 BHN	30	0.05	0.05	0.08	0.1	0.1	0.13	0.13	-	
Super Alloys, Titanium & Nickle Alloys	Titanium	24-30 HRc	40	0.06	0.06	0.1	0.13	0.13	0.16	-	-
		30-38 HRc	30	0.05	0.05	0.08	0.1	0.1	0.13	-	-
	Special Alloys	30-38 HRc	20	0.06	0.06	0.1	0.13	0.13	0.16	-	-

Material	Hardness	Cutting Speed (Vc)	FEED per REVOLUTION								
			<3 mm	4 mm	6 mm	8 mm	10 mm	12 mm	16 mm	20 mm	
		m/min	mm / rev								
Hardened Steel	Hardened Steel (<40 HRc)	<40 HRc	20	0.03	0.03	0.04	0.05	0.05	0.06	-	-

NOTE: These are just the Starting Parameters, you may vary the Speed and Feed depending upon other machining conditions.

Material	Hardness	Cutting Speed	FEED per REVOLUTION								
			<3 mm	4 mm	6 mm	8 mm	10 mm	12 mm	16 mm	20 mm	
		m/min	mm / rev								
Aluminium And Other Non Ferrous Material	Aluminium & Al-alloys	≤120 BHN	190	0.12	0.15	0.2	0.33	0.33	0.41	0.41	0.5
	Al wrought alloys	≤150 BHN	190	0.12	0.15	0.2	0.33	0.33	0.41	0.41	0.5
	Al cast alloys ≤ 10 %Si	≤200 BHN	150	0.12	0.12	0.16	0.25	0.25	0.33	0.33	0.41
	Al cast alloys > 10 %Si	≤200 BHN	120	0.08	0.12	0.16	0.25	0.25	0.33	0.33	0.41
	Magnesium alloys	≤150 BHN	170	0.08	0.12	0.16	0.25	0.25	0.33	0.33	0.41
	Copper, low-alloyed	≤120 BHN	60	0.08	0.08	0.13	0.13	0.13	0.2	0.2	0.25
	Brass, short-chipping	≤200 BHN	190	0.06	0.08	0.16	0.25	0.25	0.33	0.33	0.41
	Brass, long-chipping	≤120 BHN	120	0.05	0.08	0.13	0.2	0.2	0.25	0.25	0.33
	Bronze, short-chipping	≤200 BHN	60	0.05	0.06	0.13	0.13	0.13	0.2	0.2	0.25
	Bronze, short-chipping	>200-260 BHN	60	0.05	0.05	0.1	0.1	0.1	0.16	0.16	0.2
	Bronze, long-chipping	≤24 HRc	50	0.05	0.05	0.1	0.1	0.1	0.16	0.16	0.2
	Bronze, long-chipping	>24-30 HRc	50	0.05	0.05	0.1	0.1	0.1	0.16	0.16	0.2
	Reinforced plastics - GFK/CFK	-	-	-	-	-	-	-	-	-	-

NOTE: These are just the Starting Parameters, you may vary the Speed and Feed depending upon other environmental condition.

Material	Hardness	Cutting speed (Vc)	FEED per REVOLUTION				
			6 mm	8 mm	10 mm	12 mm	
		m/min	mm / rev				
Alloy Steel	Common Structural Steels	≤100 BHN	50	0.07	0.08	0.1	0.12
		100-180 BHN	40	0.07	0.08	0.1	0.12
	Free Cutting Steels	≤24 HRc	50	0.07	0.08	0.1	0.12
		>24-30 HRc	40	0.07	0.08	0.1	0.12
	Alloyed Heat-treatable Steels	24-30 HRc	50	0.07	0.08	0.1	0.12
		30-38 HRc	40	0.07	0.08	0.1	0.12
Tool Steels	24-30 HRc	40	0.07	0.08	0.1	0.12	
	30-38 HRc	30	0.07	0.08	0.1	0.12	
Stainless Steel	Austenitic Stainless Steel	≤24 HRc	40	0.05	0.07	0.09	0.11
	Austenitic Stainless Steel	≤24 HRc	30	0.05	0.07	0.09	0.11
	Martensitic Stainless Steel	>24 HRc	20	0.05	0.07	0.09	0.11
Cast Iron	Grey Cast Iron	≤230 BHN	80	0.07	0.08	0.1	0.12
		240-300 BHN	70	0.07	0.08	0.1	0.12
	Ductile Cast Iron	≤230 BHN	60	0.07	0.08	0.1	0.12
		240-300 BHN	55	0.07	0.08	0.1	0.12
Chilled Cast Iron	≤350 BHN	35	0.07	0.08	0.1	0.12	
Cast Iron	Titanium	24-30 HRc	15	0.04	0.06	0.08	0.1
		30-38 HRc	10	0.04	0.06	0.08	0.1
	Special Alloys	30-38 HRc	10	0.04	0.06	0.08	0.1
Hardened Steel	Hardened Steel (<40 HRc)	<40 HRc	10	0.04	0.06	0.08	0.1

NOTE: These are just the Starting Parameters, you may vary the Speed and Feed depending upon other machining conditions.

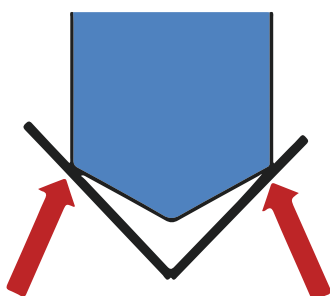

**Figure 1**  
90° Spot Angle  
135° Drill Angle  
  
Initial Contact Area Damages Carbide Drills!!

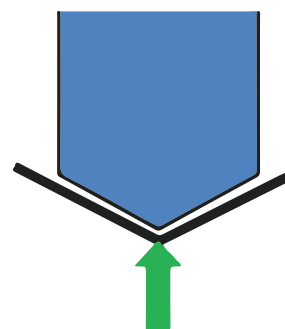

**Figure 2**  
140° Spot Angle  
135° Drill Angle  
  
Contact Is At The Drill Point

## Drill Selection

Use the shortest drill the application will permit in order to achieve maximum tool rigidity.

## HOLDERS

Tool holders and collets must provide good concentricity between the drill and the machine spindle. Use a positive back stop to prevent the tool from backing up into the holder. Never collet the tool over the flutes or over-tighten the holder. Static runout in the tool assembly must be accurately checked and maintained.

## Workpiece

A secure and rigid workpiece to minimize deflection is needed, particularly on through-hole applications.

## Coolants

Coolants are recommended when drilling mild steel and high temperature alloys. The purpose of the coolant media is to direct the chips away from the cutting tool and workpiece. Excessive coolant pressure and/or too much volume can negatively affect performance. When using coolant fed drills, the coolant pressure that is required should be higher than normal. Suggested pressure for coolant fed drills is minimally 150 PSI. As the diameter of the drill is reduced, the higher the pressure. This is to assist the chip in evacuating from a more confined area.

## Component Analysis

### Material :

- Machinability
- Chipbreaking
- Hardness

### Application Material Group = AMG :

- Steel
- Stainless Steel
- Cast Iron
- Titanium
- Nickel
- Copper/brass
- Aluminum / Magnesium
- Synthetic Materials / Plastic
- Hard Materials
- Graphite

## The Hole:

**DIAMETER**

**Wall Thickness :** Thickness is good enough or very thin

**DEPTH**

**Reach Required :** How far drill must be sticking out of the holder

**QUALITY**

**Proper Fixturing :** Clamping of the component must be proper

**Rotating or Static Operation :** Is the drill in rotation or component is in rotation.

## Solid Carbide Drilling On Inclined Surfaces

### • ENTERING OR EXITING the Workpiece :

#### ► If Entry Angle = 1° To 5°

Feed Rate To Be Reduced To 1/3 (33%)

#### ► If Entry Angle = 5° To 10°

Feed Rate To Be Reduced To Between 1/3 (33%) & 1/4 (25%)

#### Suggestions :

Perform Centring Operation with a Short Spotting Drill Firstly which has a same or a Greater Point angle. This minimizes the deflection and extends the Tool life. (\*Refer Fig.1 and Fig.2 on Pg.58)

#### ► If Entry Angle is Larger Than 10°

Direct Entry With Solid Carbide Drill Not Recommended

#### Suggestions :

Caution: Never use our C3HS or CTHS Carbide Drills directly on an inclined surface with Entry angle steeper than 10°. Firstly do milling with our 301 or 322- Series Flat end mill to make a Flat Surface, and then with our recommended parameters do the drilling with either C3HS-High Performance Carbide Drills Or CTHS Coolant Fed Drills

#### ► If EXIT SURFACE is Angled

Feed Rate To Be Reduced To Between 1/3 (33%) & 1/4 (25%)

Extremely Steep Angles may still cause chipping on the Solid Carbide Drill's Lips or outside corner

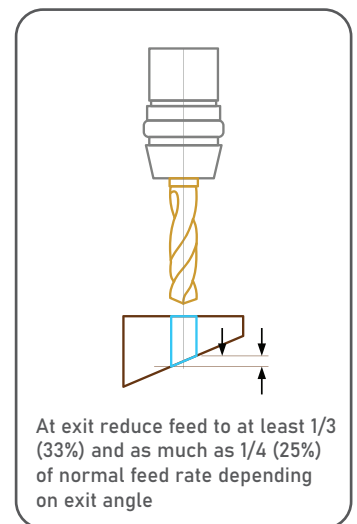
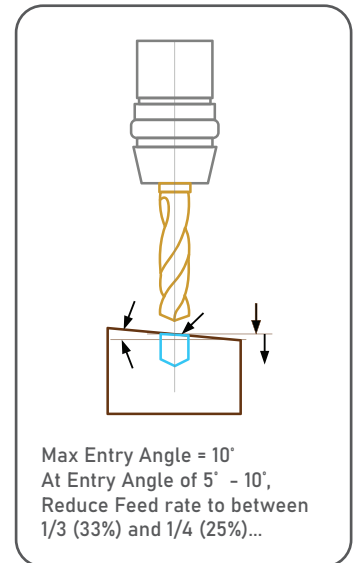

## Solid Carbide Drilling On Irregular Surfaces

### • ENTERING OR EXITING the Workpiece :

Feed Rate To Be Reduced To 1/4 (25%)\*

Extremely Rough Surfaces with scale and hard spots may still cause chipping on the Solid Carbide Drill's Lips or outside corners.

#### Suggestions :

Inspect the drill often to be sure chipping will not compromise hole quality

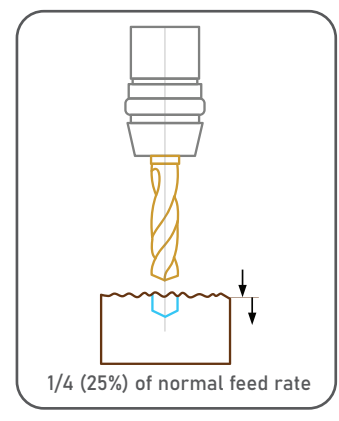

## Solid Carbide Drilling On Concave Surfaces

### • ENTERING OR EXITING the Workpiece :

If the part radius is larger than 15 X Drill Diameter

Feed Rate To Be Reduced To 1/3 (33%)

If the part radius is smaller than 15 x Drill Diameter, this is not highly recommended but can be successful in some easy to machine materials (for ex: Aluminum)

### Suggestions :

For Curved surface drilling we recommend Flat Bottom Drills.  
Contact our RIGPL representative for quote.

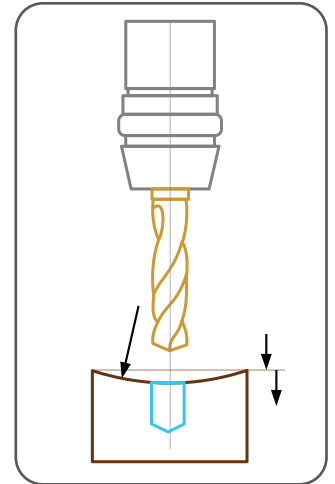

## Solid Carbide Drilling On Convex Surfaces

### • ENTERING OR EXITING the Workpiece :

If the part radius is larger than 4 X Drill Diameter

Feed Rate To Be Reduced To 1/2 (50%)

If the part radius is smaller than 4 x Drill Diameter, this is not highly recommended because drill will most likely walk and will not center properly.

### Suggestions :

For Curved surface drilling we recommend Flat Bottom Drills.  
Contact our RIGPL representative for quote.

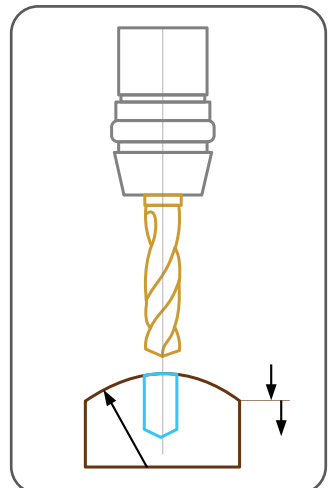

## Solid Carbide Cross Hole Drilling

### • ENTERING OR EXITING a Cross Hole in the Workpiece :

Feed Rate To Be Reduced To 1/4 (25%) from entering till exiting of cross-hole region Once drill is fully engaged, increase the feed rate back to recommended parameters

### Suggestions :

For Cross hole drilling we recommend Double Margin Drills.  
Contact our RIGPL representative for quote.

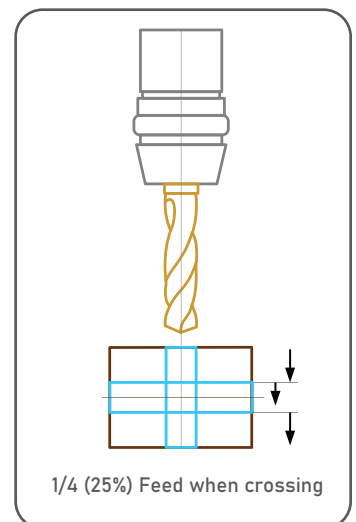



## Solid Carbide Stack Drilling

- If the stacked plates are clamped tightly together & gaps are eliminated :

Feed Rate reduction is not required.

- If small gaps remain between the stacked plate :

### Suggestions :

Industrial paper shims can be used between stacks to level out the irregularities and reduce the vibrations.

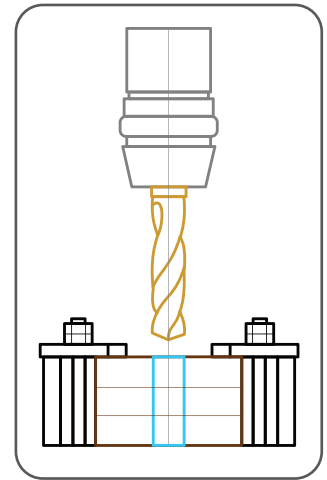

## Best Machining Practice

### Use of Hydro-Grip or Precision Collet

- By providing even tool grip it reduces runout and tool slip under high rpm and load variation.

#### Benefits

- ▶ Runout control is much better
- ▶ Lower the run out better the Tool Life
- ▶ Higher Productivity
- ▶ Lower Part Rejections

### Clean Tool Holder

- Proper cleaning of tool holder assembly before mounting of new tool to remove fine chips.

#### Benefits

- ▶ Prevents from avoidable runout
- ▶ Less chances of tool breakage

For more details please read our blog for Best way to use High Performance Carbide Drills.

## Check Tool and Spindle Runout

Tool Runout : 12 $\mu$  or less

Spindle Runout : 4 $\mu$  or less

Puppy Dial with least count of 2 $\mu$  or less should be used for accuracy.

### Benefits

- ▶ Prevents uneven tool wear
- ▶ Prevents oversizing issue
- ▶ Increases Tool Life & productivity (Lower run-out, higher tool life)

## Coolant Pressure & Concentration

Pressure : At least 6 Bar or more is better.

Concentration : At least 5% or mentioned.

### Benefits

- ▶ Prevents tool buildup edge and Improves component Surface Finish.
- ▶ Helps in improving productivity

## Cleaning for Workpiece Rigidity

- Metal chips removal from tool and work holding device especially component sitting area and around with either pressurised air or coolant to avoid any potential misalignment.

### Benefits

- ▶ Prevents from potential component rejection
- ▶ Prevents premature Tool damage / failure due to improper rigidity

## Using Troubleshooting Table

- If even after applying above 'Best Machining Practice' problem persist use troubleshooting tables as per application from tool manufacturer's catalog

### Benefits

- ▶ To solve any Potential problem

For more details please read our blog for Best way to use High Performance Carbide Drills.

## Cutting edge build-up

### Cause :

- Low cutting speed
- Excessive honing of cutting lip
- Bright finish cutting lip

### Remedy :

- Increase cutting speed
- Reduce cutting lip honing
- Have tool coated

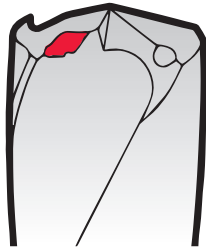

## Heavy wear and tear at flank

### Cause :

- Cutting speed too high
- Feed too low
- Clearance angle too small

### Remedy :

- Decrease cutting speed
- Increase feed
- Increase clearance angle

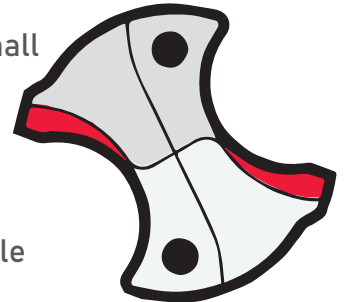

## Crumbling of outer corners

### Cause :

- Non-rigid conditions, insufficient work piece clamping
- Excessive deviation from concentricity
- Interrupted cut

### Remedy :

- Rigid clamping of work piece
- Check and correct concentricity if possible
- Reduce feed

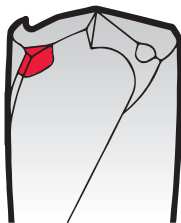

## Crumbling on cutting lips

### Cause :

- Non-rigid conditions, insufficient work piece clamping
- Interrupted cut
- Maximum wear and tear values have been exceeded
- Wrong tool type

### Remedy :

- Rigid clamping of work piece
- Reduce feed
- Reduce tool change intervals
- Apply suitable tool

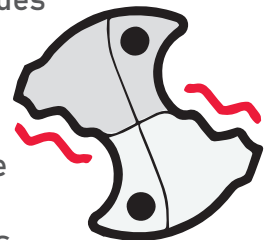

## Land wear

### Cause:

- Non-rigid conditions, insufficient work piece clamping
- Large deviation from concentricity
- Back taper too small
- Wrong coolant/lubrication (oil), soluble oil too thin

### Remedy :

- Rigid clamping of work piece
- Check and correct concentricity if possible
- Increase back taper
- Thicken soluble oil or use neat oil

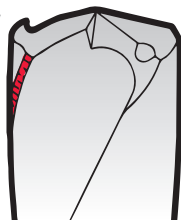

## Scoring on tool body

### Cause:

- Non-rigid conditions, insufficient work piece clamping
- Large deviation from concentricity
- Interrupted cut
- Abrasive work piece material

### Remedy :

- Rigid clamping of work piece
- Check and correct concentricity if possible
- Reduce feed
- Thicken soluble oil or use neat oil

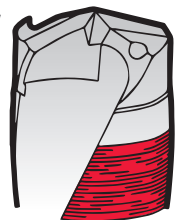

## Heavy chisel edge wear & tear

### Cause :

- Cutting speed too low
- Feed too high
- Excessive honing of cutting lip

### Remedy :

- Increase cutting speed
- Decrease feed
- Reduce cutting lip honing

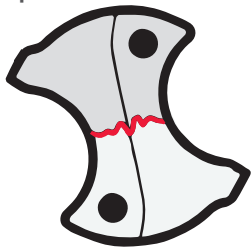

## Crumbling at intersection of web thinning and cutting lip

### Cause :

- Clearance angle too small
- Excessive honing of cutting lip
- Wrong tool type

### Remedy :

- Increase clearance angle
- Reduce cutting lip honing
- Apply suitable tool

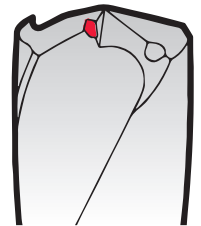

## Plastic deformation of outer corner

### Cause :

- Cutting speed too high
- Incorrect or no honing at corner
- Incorrect or no corner chamfer

### Remedy :

- Decrease cutting speed
- Correct honing
- Apply correct corner chamfer

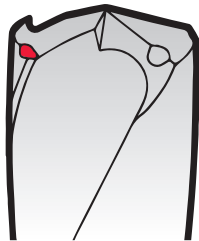

## Misalignment, axis shifting

### Cause :

- Non-rigid conditions, insufficient work piece clamping
- Excessive deviation from concentricity
- Spotting area transverse
- Chisel edge too large

### Remedy :

- Rigid clamping of work piece
- Check and correct concentricity, if possible
- Use twin-fluted milling cutter for spotting
- Reduce chisel edge

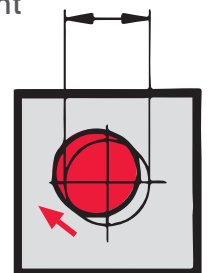

## Heavy burring on breakthrough

### Cause:

- Feed too high
- Maximum wear and tear values have been exceeded
- Excessive honing of cutting lip

### Remedy :

- Decrease feed
- Reduce tool change intervals
- Reduce cutting lip honing

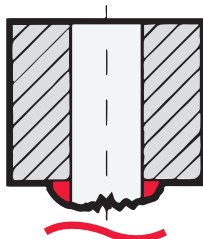

## Unsatisfactory surface quality

### Cause:

- Non-rigid conditions, insufficient work piece clamping
- Excessive deviation from concentricity
- Insufficient coolant

### Remedy :

- Rigid clamping of work piece
- Check and correct concentricity, if possible
- Increase coolant (volume, pressure)

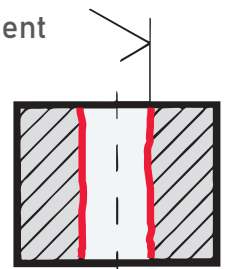

## Carbide Reamers

In applications that require high-precision hole finishes, or tighter diameter control ROHIT's Solid Carbide Reamers can be used with confidence in a wide range of sizes for virtually all materials, including cast iron, aluminium, stainless steel, exotic alloys, plastics and other non-ferrous materials.

Description	Series No.	Page No
Carbide St. Flute Reamers	C1RS	69
Carbide LHS/RHC Reamers	C1RL	71
Carbide RHS/RHC Reamers	C1RR	73
Technical Information	Troubleshooting	75



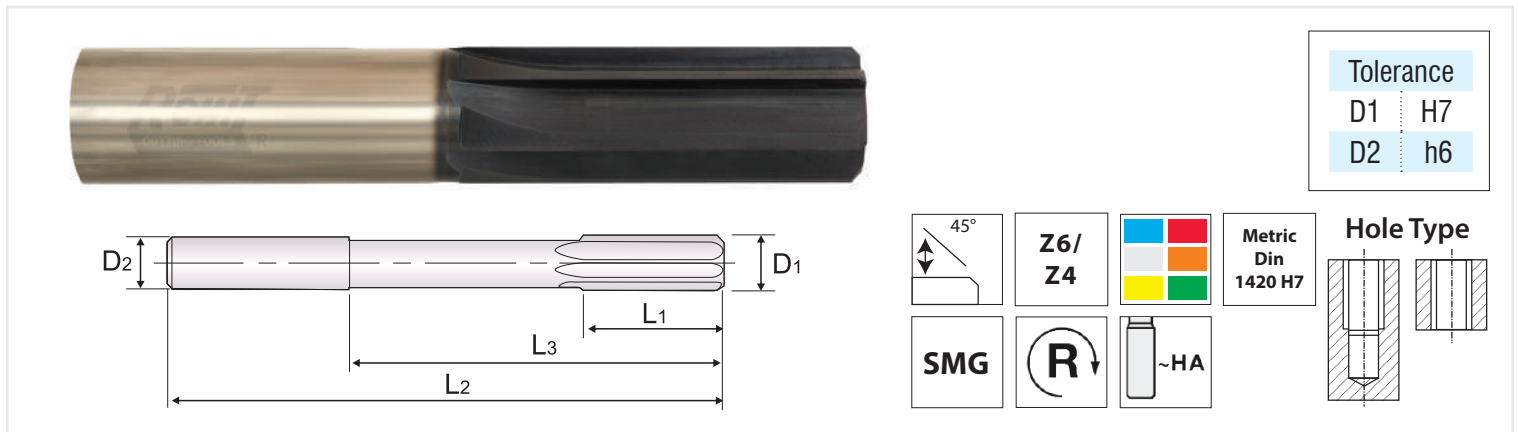

Tolerance	
D1	H7
D2	h6

## Applications:

- Best suited for General Purpose Reaming in ferrous & non-ferrous materials
- Suited for both Through & blind hole construction
- Special sizes available on request

## Features:

- Accurate Size Great Finish
- Manufactured with in 2-3 micron accuracy
- Gives accurate hole size and high finishing

Ordering Code (Uncoated)	Ordering Code (TiAlN Coated)	Flute Dia (D1)	Flute Len (L1)	Reach Len (L3)	Overall Len (L2)	Shank Dia (D2)	# of Flutes
C1RS0300061-U	C1RS0300061-F	3	15	31	61	4	4
C1RS0350070-U	C1RS0350070-F	3.5	18	36	70	4	4
C1RS0400075-U	C1RS0400075-F	4	19	42	75	4	4
C1RS0450080-U	C1RS0450080-F	4.5	21	46	80	5	4
C1RS0500086-U	C1RS0500086-F	5	23	51	86	5	4
C1RS0550093-U	C1RS0550093-F	5.5	26	56	93	6	4
C1RS0600093-U	C1RS0600093-F	6	26	56	93	6	4
C1RS0650101-U	C1RS0650101-F	6.5	28	62	101	7	6
C1RS0700109-U	C1RS0700109-F	7	31	68	109	7	6
C1RS0750109-U	C1RS0750109-F	7.5	31	68	109	8	6
C1RS0800117-U	C1RS0800117-F	8	33	74	117	8	6
C1RS0850117-U	C1RS0850117-F	8.5	33	74	117	9	6
C1RS0900125-U	C1RS0900125-F	9	36	80	125	9	6

Ordering Code (Uncoated)	Ordering Code (TiAlN Coated)	Flute Dia (D1)	Flute Len (L1)	Reach Len (L3)	Overall Len (L2)	Shank Dia (D2)	# of Flutes
C1RS0950125-U	C1RS0950125-F	9.5	36	80	125	10	6
C1RS1000133-U	C1RS1000133-F	10	38	86	133	10	6
C1RS1050133-U	C1RS1050133-F	10.5	38	86	133	12	6
C1RS1100142-U	C1RS1100142-F	11	41	95	142	12	6
C1RS1200151-U	C1RS1200151-F	12	44	104	151	12	6
C1RS1300151-U	C1RS1300151-F	13	44	104	151	14	6
C1RS1400155-U	C1RS1400155-F	14	47	106	155	14	6
C1RS1500160-U	C1RS1500160-F	15	50	110	160	16	6
C1RS1600160-U	C1RS1600160-F	16	52	110	160	16	6



Carbon Steels BHN 180 to 225	Alloy Steels BHN 225 to 355	Pre-hardened Steels HRC 40 to 45	Austenitic Stainless Steel	Precipitation Hardened Stainless Steel	Titanium	HighTemp. Alloy	Grey Cast Iron	Ductile Cast Iron	Hardened Steels HRC 45 to 55	High Hardened Steels HRC 55 to 70	Aluminum	Aluminum Alloys	Plastic	Wood / MDF	Copper / Brass
1 <sup>st</sup>	1 <sup>st</sup>	1 <sup>st</sup>	1 <sup>st</sup>	1 <sup>st</sup>	1 <sup>st</sup>	1 <sup>st</sup>	1 <sup>st</sup>	1 <sup>st</sup>			1 <sup>st</sup>	1 <sup>st</sup>			1 <sup>st</sup>

NOTE: This is Non-stock Item, ask your RIGPL representative for Delivery Period  
FOR FEED & SPEED Rates, go to page no. PG-77 to 78

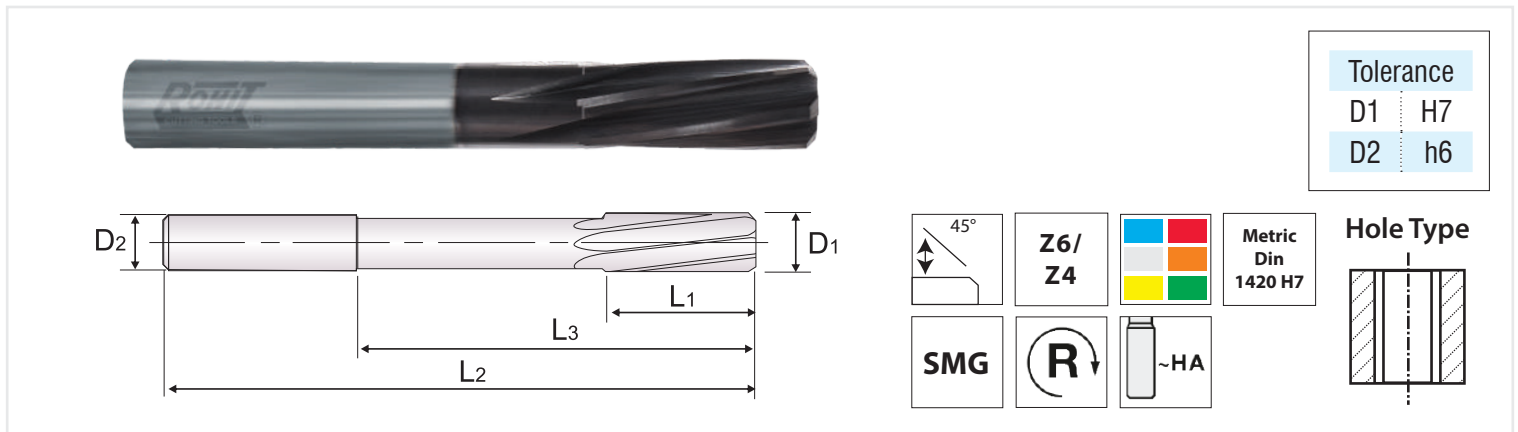

Tolerance	
D1	H7
D2	h6

45°	Z6/ Z4		Metric Din 1420 H7	Hole Type 
SMG				

## Applications:

- Best suited for General Purpose Reaming in ferrous & non-ferrous materials
- Suited for through hole construction
- Special sizes available on request

## Features:

- Accurate Size Great Finish
- Manufactured with in 2-3 micron accuracy
- Gives accurate hole size and high finishing

Ordering Code (Uncoated)	Ordering Code (TiAlN Coated)	Flute Dia (D1)	Flute Len (L1)	Reach Len (L3)	Overall Len (L2)	Shank Dia (D2)	# of Flutes
C1RL0300061-U	C1RL0300061-F	3	15	31	61	4	4
C1RL0350070-U	C1RL0350070-F	3.5	18	36	70	4	4
C1RL0400075-U	C1RL0400075-F	4	19	42	75	4	4
C1RL0450080-U	C1RL0450080-F	4.5	21	46	80	5	4
C1RL0500086-U	C1RL0500086-F	5	23	51	86	5	4
C1RL0550093-U	C1RL0550093-F	5.5	26	56	93	6	4
C1RL0600093-U	C1RL0600093-F	6	26	56	93	6	4
C1RL0650101-U	C1RL0650101-F	6.5	28	62	101	7	6
C1RL0700109-U	C1RL0700109-F	7	31	68	109	7	6
C1RL0750109-U	C1RL0750109-F	7.5	31	68	109	8	6
C1RL0800117-U	C1RL0800117-F	8	33	74	117	8	6
C1RL0850117-U	C1RL0850117-F	8.5	33	74	117	9	6
C1RL0900125-U	C1RL0900125-F	9	36	80	125	9	6



Ordering Code (Uncoated)	Ordering Code (TiAlN Coated)	Flute Dia (D1)	Flute Len (L1)	Reach Len (L3)	Overall Len (L2)	Shank Dia (D2)	# of Flutes
C1RL0950125-U	C1RL0950125-F	9.5	36	80	125	10	6
C1RL1000133-U	C1RL1000133-F	10	38	86	133	10	6
C1RL1050133-U	C1RL1050133-F	10.5	38	86	133	12	6
C1RL1100142-U	C1RL1100142-F	11	41	95	142	12	6
C1RL1200151-U	C1RL1200151-F	12	44	104	151	12	6
C1RL1300151-U	C1RL1300151-F	13	44	104	151	14	6
C1RL1400155-U	C1RL1400155-F	14	47	106	155	14	6
C1RL1500160-U	C1RL1500160-F	15	50	110	160	16	6
C1RL1600160-U	C1RL1600160-F	16	52	110	160	16	6

### What is Machinability and Machinability Index or Rating?

Machinability is the ease with which a Cutting Tool can machine a workpiece material. Machinability ratings (MR) provide understanding of the severity of a metalworking operation in comparison to B1112 steel as the base material whose MR is taken as 1.0. So Lower the MR poor is the machinability of the material.

[Read More on rigpl.com/blog](http://rigpl.com/blog)

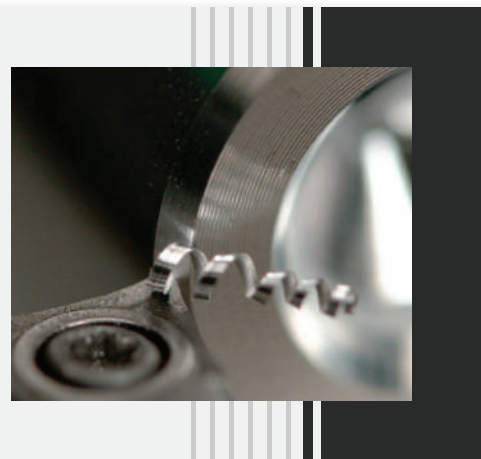

Carbon Steels BHN 180 to 225	Alloy Steels BHN 225 to 355	Pre-hardened Steels HRC 40 to 45	Austenitic Stainless Steel	Precipitation Hardened Stainless Steel	Titanium	HighTemp. Alloy	Grey Cast Iron	Ductile Cast Iron	Hardened Steels HRC 45 to 55	High Hardened Steels HRC 55 to 70	Aluminum	Aluminum Alloys	Plastic	Wood / MDF	Copper / Brass
1 <sup>st</sup>	1 <sup>st</sup>	1 <sup>st</sup>	1 <sup>st</sup>	1 <sup>st</sup>	1 <sup>st</sup>	1 <sup>st</sup>	1 <sup>st</sup>	1 <sup>st</sup>			1 <sup>st</sup>	1 <sup>st</sup>			1 <sup>st</sup>

NOTE: This is Non-stock Item, ask your RIGPL representative for Delivery Period  
FOR FEED & SPEED Rates, go to page no. PG-77 to 78

Selection-Guide

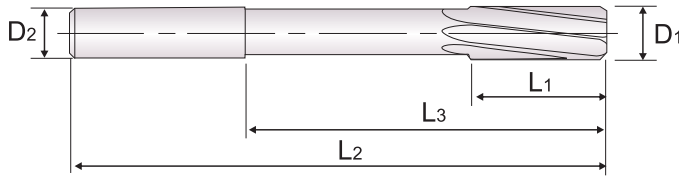

Tolerance	
D1	H7
D2	h6

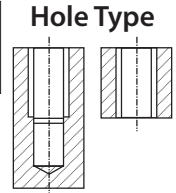

## Applications:

- Best suited for General Purpose Reaming in ferrous & non-ferrous materials
- Suited for both Through & blind hole construction
- Special sizes available on request

## Features:

- Accurate Size Great Finish
- Manufactured with in 2-3 micron accuracy
- Gives accurate hole size and high finishing

Ordering Code (Uncoated)	Ordering Code (TiAlN Coated)	Flute Dia (D1)	Flute Len (L1)	Reach Len (L3)	Overall Len (L2)	Shank Dia (D2)	# of Flutes
C1RR0300061-U	C1RR0300061-F	3	15	31	61	4	4
C1RR0350070-U	C1RR0350070-F	3.5	18	36	70	4	4
C1RR0400075-U	C1RR0400075-F	4	19	42	75	4	4
C1RR0450080-U	C1RR0450080-F	4.5	21	46	80	5	4
C1RR0500086-U	C1RR0500086-F	5	23	51	86	5	4
C1RR0550093-U	C1RR0550093-F	5.5	26	56	93	6	4
C1RR0600093-U	C1RR0600093-F	6	26	56	93	6	4
C1RR0650101-U	C1RR0650101-F	6.5	28	62	101	7	6
C1RR0700109-U	C1RR0700109-F	7	31	68	109	7	6
C1RR0750109-U	C1RR0750109-F	7.5	31	68	109	8	6
C1RR0800117-U	C1RR0800117-F	8	33	74	117	8	6
C1RR0850117-U	C1RR0850117-F	8.5	33	74	117	9	6
C1RR0900125-U	C1RR0900125-F	9	36	80	125	9	6

Ordering Code (Uncoated)	Ordering Code (TiALN Coated)	Flute Dia (D1)	Flute Len (L1)	Reach Len (L3)	Overall Len (L2)	Shank Dia (D2)	# of Flutes
C1RR0950125-U	C1RR0950125-F	9.5	36	80	125	10	6
C1RR1000133-U	C1RR1000133-F	10	38	86	133	10	6
C1RR1050133-U	C1RR1050133-F	10.5	38	86	133	12	6
C1RR1100142-U	C1RR1100142-F	11	41	95	142	12	6
C1RR1200151-U	C1RR1200151-F	12	44	104	151	12	6
C1RR1300151-U	C1RR1300151-F	13	44	104	151	14	6
C1RR1400155-U	C1RR1400155-F	14	47	106	155	14	6
C1RR1500160-U	C1RR1500160-F	15	50	110	160	16	6
C1RR1600160-U	C1RR1600160-F	16	52	110	160	16	6



Carbon Steels BHN 180 to 225	Alloy Steels BHN 225 to 355	Pre-hardened Steels HRC 40 to 45	Austenitic Stainless Steel	Precipitation Hardened Stainless Steel	Titanium	HighTemp. Alloy	Grey Cast Iron	Ductile Cast Iron	Hardened Steels HRC 45 to 55	High Hardened Steels HRC 55 to 70	Aluminum	Aluminum Alloys	Plastic	Wood / MDF	Copper / Brass
1 <sup>st</sup>	1 <sup>st</sup>	1 <sup>st</sup>	1 <sup>st</sup>	1 <sup>st</sup>	1 <sup>st</sup>	1 <sup>st</sup>	1 <sup>st</sup>	1 <sup>st</sup>			1 <sup>st</sup>	1 <sup>st</sup>			1 <sup>st</sup>

NOTE: This is Non-stock Item, ask your RIGPL representative for Delivery Period  
FOR FEED & SPEED Rates, go to page no. PG-77 to 78

Problem	Possible Solution																
	Speed & Feed						Tool Geometry						Coolant & Stock Removal				
	Reduce Feed	Increase Feed	Reduce Speed	Increase Speed	Use Larger Reamer	Use Smaller Reamer	Bad Speed & Feed	Worn Tool Margin	Worn Cutting Edge	Uneven Lip Height	Chip Capacity of Reamer	Too Much Clearance	Grind Larger Back Taper	Bent Reamer	Insufficient Stock	Too Much Stock	Use Coolant
Burnishing		X									X				X		
Reamer Wear	X		X				X									X	X
Hole Quality	X		X				X	X	X	X					X	X	X
Hole Undersize	X		X		X	X		X	X						X	X	X
Hole Oversize		X		X		X		X	X					X		X	X
Accuracy	X									X							X
Chatter		X	X							X	X	X			X		X
Out of Round Hole								X	X	X					X	X	X
Hole Taper						X		X	X	X			X			X	X
Bell Mouth		X					X	X	X			X	X				X
Reamer Life		X	X				X			X	X	X					X
Scoring in Bore							X	X	X	X					X	X	X
Deflection																	

Possible Solution																				
Coolant & Stock Removal						Set Up										Cutting Errors				
Run Dry	Poor Hole Prep	Insufficient Stock	Too Much Stock	Use Coolant	Run Dry	Poor Hole Prep	Alignment	Holder Accuracy	Concentricity	Use Adjustable Holder	Use Floating Holder	Lack of Rigidity in Set-Up	Work Holding Error	Spindle Bearings	Tool Extended Too Far	Poor Regrind	Poor Machinability	Built Up Edge	Wrong Tool	Poor Chip Removal
		X					X						X			X				
	X		X	X		X	X	X					X			X	X			X
	X	X	X	X		X	X		X				X			X	X	X	X	
		X	X	X			X										X			
X	X		X	X	X	X	X		X				X			X	X	X	X	
				X									X			X				
		X		X			X	X				X	X	X	X	X				
		X	X	X			X						X			X				
			X	X			X	X	X	X	X		X			X	X	X		
			X	X			X	X	X	X		X			X	X				
	X	X	X	X		X			X								X	X		X
							X													

Material	Example	Drill Size (mm)							
		2.8	3.8	4.8	5.8	7.8	9.8	11.8	15.7
		Reamer Diameter (mm)							
		3	4	5	6	8	10	12	16
		Total Stock Allowance							
Magnesium		0.2	0.22	0.22	0.23	0.26	0.3	0.32	0.38
Aluminium	<5%SI	0.2	0.22	0.22	0.23	0.26	0.3	0.32	0.38
	>5%SI	0.2	0.22	0.22	0.23	0.24	0.26	0.29	0.33
Brass & Soft Bronze	Brass	0.2	0.22	0.22	0.23	0.24	0.26	0.29	0.33
	Bronze	0.2	0.22	0.22	0.23	0.25	0.28	0.3	0.35
Copper & Hard Bronze		0.2	0.22	0.22	0.23	0.25	0.28	0.3	0.35
Cast Iron	Cast	0.17	0.19	0.2	0.21	0.23	0.25	0.27	0.33
	Ductile	0.17	0.19	0.2	0.21	0.23	0.25	0.27	0.3
Steel	<35 HRc	0.17	0.19	0.2	0.21	0.23	0.25	0.27	0.33
	>35HRc	0.14	0.16	0.17	0.18	0.2	0.23	0.24	0.3
	Tool STEEL	0.14	0.16	0.17	0.18	0.2	0.23	0.24	0.3
	Hard	0.1	0.12	0.12	0.13	0.15	0.18	0.19	0.25
Stainless Steel		0.14	0.16	0.17	0.18	0.2	0.23	0.24	0.3
High Temp Alloys	Soft	0.14	0.16	0.17	0.18	0.19	0.21	0.24	0.28
	Hard	0.13	0.14	0.15	0.16	0.16	0.18	0.21	0.25
Titanium		0.17	0.19	0.2	0.21	0.23	0.25	0.27	0.33

## Material Removal Parameters

For proper finishing with a reamer, the correct amount of material must be left in the hole. If the hole is too close to the finish size, the reamer will tend to burnish the hole, and excessive tool wear will occur. If too much material is left, chips can clog the flutes of the reamer, resulting in a poor finish, poor size control, and possible tool breakage.

Series : C1RS, C1RR, C1RL		Diameter(mm)					
				>1.5 - 3.0	>3.0 - 6.0	>6.0 - 12.0	>12.0-25.0
Material	ISO	Examples	Vc	Feed per rev (mm/rev)			
Steels	P	Free Cutting Steels	45-70	0.035-0.100	0.070-0.175	0.100-0.280	0.175-0.550
		Alloyed Heat-treatable Steels	30-45	0.035-0.070	0.070-0.100	0.100-0.175	0.175-0.350
		Tool Steels 4140/a2/d2	12-30	0.020-0.035	0.035-0.070	0.070-0.100	0.100-0.175
Stainless Steels	M	Austenitic Stainless Steel (304,310)	27-45	0.035-0.070	0.070-0.100	0.100-0.175	0.175-0.350
		Austenitic Stainless Steel	A18-28	0.035-0.070	0.070-0.100	0.100-0.175	0.175-0.350
		Martensitic Stainless Steel	15-25	0.020-0.070	0.035-0.100	0.070-0.175	0.100-0.350
Special Alloys	S	Inconel 625/718	10-15	0.020-0.035	0.035-0.070	0.070-0.100	0.100-0.175
		Stellite/cobalt Chrome	7-12	0.020-0.035	0.035-0.070	0.070-0.100	0.100-0.175
		Titanium 6al-4v	7-12	0.020-0.070	0.035-0.100	0.070-0.175	0.100-0.350
Cast Iron	K	Gray Cast Iron A48 Class 20/G4000	35-60	0.020-0.070	0.035-0.100	0.070-0.175	0.100-0.350
		Malleable/Ductile Cast Iron A536/60-40-18	35-45	0.035-0.070	0.070-0.100	0.100-0.175	0.175-0.350
		Hard (Martensitic) Cast Iron	12-20	0.020-0.035	0.035-0.070	0.070-0.100	0.100-0.175
Non-Ferrous	N	Aluminium/Aluminium Alloys	150-300	0.035-0.100	0.070-0.175	0.100-0.280	0.175-0.550
		Brass/Bronze Free Ma-chining	75- 120	0.035-0.070	0.070-0.100	0.100-0.175	0.175-0.350
		Brass/Bronze (Hard)	45-75	0.035-0.070	0.070-0.100	0.100-0.175	0.175-0.350
		Magnesium/ Magnesium Alloys/Plastics Bakelite Plastic-Glass	110-220	0.035-0.100	0.070-0.175	0.100-0.280	0.175-0.550
		Copper/Hard Bronze	20-35	0.020-0.035	0.035-0.070	0.070-0.100	0.100-0.175
Hardened Steel	H	"Hardened Steels 23-32 HRc"	30-45	0.035-0.070	0.070-0.100	0.100-0.175	0.175-0.350
		"Hardened Steels 32-43 HRc"	10-30	0.020-0.035	0.035-0.070	0.070-0.100	0.100-0.175
		"Hardened Steels 43-52 HRc"	7-12	0.020-0.035	0.035-0.070	0.070-0.100	0.100-0.175

NOTE: These are just the Starting Parameters, you may vary the Speed and Feed depending upon other machining conditions.